

CONFIDENTIAL

Psychology Department Handbook

Last updated: December 2020

Contents

An Introduction to the Department of Psychology	3
Faculty	4
Courses	6
Undergraduate student section: Majors, minors, ASP	15
MLS section	25
PhD section	29
Psychology PhD Program Student Handbook	29
Faculty handbook	37
Undergraduate Education	37
Graduate Education	39
Best Practices in Teaching	40
Teaching guidelines for hallmark courses for the department	40
Administration	45
Annual Administrative Workplan	46
Academic Advisory Board student representative	50
Departmental Awards	50
Research	51
Promotion & Tenure	53
Faculty Recruitment	54
Invitation for external candidates	55
References	56
Appendices	57
Facts and Figures	87

An Introduction to the Department of Psychology

Psychology at Ashoka University is organized around a scientific approach to the study of behaviour. Students are encouraged to develop scientific investigative and analytical skills that enable critical thinking and statistically sound research work in the field. The Department of Psychology is committed to a cross-disciplinary study of the subject, spanning different domains of psychology, and faculty expertise is representative of this cross-disciplinary approach. Faculty members have diverse areas of research and teaching interest, including social and developmental psychology, biological, cognitive, and clinical and counselling psychology. Courses offered by the department give students an understanding of all of these core domains, and enable students to explore specialised elective courses within any of these domains. Our department will create a conducive academic climate for intellectual growth, both for ourselves and for our students. We will also create an inclusive space, and one where an understanding of neurodiversity is used to critically examine unscientific pathological frameworks. The department's culture aims to be one of mutual respect and consultation among students and faculty, whether in research, pedagogy or administration.

This handbook will have separate sections for:

All students

UG research students

MLS students

PhD students

Faculty

Faculty

- **Avantika Bhatia**

Avantika Bhatia received her PhD in Counseling Psychology from the University of Maryland (UMD), College Park. Prior to the PhD, she received a Master's in Rehabilitation Counseling, also from UMD, and a Master's in Clinical Psychology from Delhi University.



- **Bittu Kaveri Rajaraman**

Prior to joining Ashoka University, Dr. Kaveri Rajaraman Indira (Bittu) was an INSPIRE-faculty at the Central University of Hyderabad. Bittu received a PhD from Harvard University in neuroscience, studying intrinsic photosensitivity in salamander retinæ. He was then a DST-Dr. D. S. Kothari postdoctoral fellow at the Center for Ecological Sciences, Indian Institute of Science, where he studied the evolution of neural and behavioral systems of communication among Orthopteran insects in response to ecological constraints.



- **Madhavalatha Maganti-Kari**

Madhavalatha Maganti-Kari is a developmental psychologist interested in studying typical and atypical development in infants and children. Specifically, her research interests are focused on understanding the developmental course of inter-sensory perception in preterm infants, and verb-acquisition in children. Further, she is interested in examining how early intervention can ameliorate perceptual delays associated with prematurity and other concomitant risk factors.



- **Rashmi Nair**

Before joining Ashoka, Dr. Nair worked at the U.S. Congress through a competitively awarded fellowship dually supported by the Society for the Psychological Study of Social Issues and the American Association for the Advancement of Science. Dr. Nair received a Ph.D. in Social Psychology from Clark University and Masters in Clinical Psychology from Christ University.



- **Simantini Ghosh**

Simantini (Simi) Ghosh did her bachelors in Physiology (Hons) from Presidency College, Calcutta. She obtained her Masters' degree in Biochemistry from the University of Calcutta and her PhD in Neurobiology and Anatomy from the University of Rochester School of Medicine and Dentistry in Rochester, New York. As a postdoctoral research scholar in Neurology in Washington School of Medicine in St. Louis, Missouri, she worked on an NIH-funded project to study behavioral effects of repetitive concussive traumatic brain injury and Alzheimer's disease brain-derived fractions in rodents. During her PhD, she taught extensively to a diverse audience of undergraduate, medical and graduate students and trained lab personnel and eventually discovered the joy in teaching and interacting with minds that are impressionable. Outside work she enjoys reading, listening to classic and alternative rock, jazz and blues, writing and photography.



- **Sramana Majumdar**

Sramana has taught at the School of Human Studies, Ambedkar University, Delhi. She completed her PhD from the Department of Psychology, Jamia Millia Islamia where she worked on exposure to political conflict, collective violence and youth in Kashmir. Her research interests include the socio-psychological analysis of large-scale conflict and related experiences of political violence among youth. Presently she is working on intergroup contact, prejudice and identity performance in computer-mediated communication. Her areas of specialization and interest are social psychology, intergroup relations, gender, psychology and conflict, political psychology, community psychology, research methodology, cultural and critical psychology.



- **Bhismadev Chakrabarti**

Bhismadev Chakrabarti is a Professor of Neuroscience and Mental Health and Research Director of the Centre for Autism at the University of Reading, UK. After a first degree in Chemistry at St. Stephen's College, India, he went to Trinity College, Cambridge, where he completed his Ph.D. in affective neuroscience. His research focuses on the core processes underlying human social behaviour, and individual differences therein. His lab uses a range of techniques to measure behaviour, autonomic, and neural activity. In parallel to his lab-based work, Prof Chakrabarti has been developing tools for neurodevelopmental assessments in low-resource settings, that can be administered by non-specialists using mobile devices. His research is funded by grants from the Medical Research Council UK, Leverhulme Trust, British Council, and the European Research Council. In recognition of his contributions, he was awarded the Philip Leverhulme Prize in Psychology, and elected to the fellowship of the Young Academy of Europe.



- **Swathi Swaminathan**

Swathi Swaminathan is a cognitive and developmental psychologist whose research seeks to understand how musical and other artistic endeavours relate to cognitive development and change across the lifespan using a combination of basic research (carried out in lab settings) and applied research (carried out in community settings). For example, in some of her work she explores basic theory-focused questions such as the modularity (or relative independence) of music and language in children and adults' minds, and the relative contributions of training and aptitude in the development of musical and other cognitive skills. She also works on applied research asking whether arts interventions, including virtual ones, can improve the wellbeing of older adults in the community or in care settings by improving their access to art in museums and arts-based recreation more generally. She received her doctoral degree in psychology from the University of Toronto (Canada), and master's degrees in experimental and clinical psychology from the University of Oxford (U.K.) and Christ University (India), respectively.



Besides being a central focus of her research life, music is also a constant avenue of personal learning. Currently, Dr. Swaminathan trains in an old form of North Indian classical music called Dhrupad with the renowned singer and generous teacher, Pt. Uday Bhawalkar, and sings when she can in jazz, blues, and bluegrass bands.

- **Tripura Kashyap**

Tripura Kashyap pioneered Dance Movement Therapy in India in 1990. She studied the discipline at the Hancock Centre for Dance/Movement Therapy in Wisconsin, USA and obtained an M.A. in Psychology in India. She passed out with a first-class diploma in Bharatanatyam from Kalakshetra college of fine arts, Chennai and was a performing artist with the Chandralekha Dance Company for many years. She has worked as a Movement therapist at Half-way homes, Special schools, Treatment / Rehabilitation centres, Senior citizens facilities and with individual clients. She also trained in Jazz, Ballet, Modern dance, Choreography and Dance theatre at the International Choreographers Residency of the 'American Dance Festival' USA. She co-founded the Creative Movement Therapy Association of India (CMTAI) in 2014.



Tripura received the Ashoka fellowship from Ashoka Innovators for the Public and scholarships from the Indian Ministry of Culture for her innovations in Dance Movement Therapy and Contemporary dance. She authored 'My Body, My Wisdom' a handbook on Creative dance therapy and 'Contemporary Dance: Practices, Paradigms and Practitioners' published by Penguin and Aayu publications. She was the founder-director of Rainbow Inc (Hyderabad) and Apoorva Dance Theatre (Bengaluru). She has worked collaboratively with filmmakers, visual artists and musicians on cross-art projects and performances. She was the project coordinator for Bhoomika dance Company (Delhi) and consultant for 'Dance-in-Education' program at Attakkalari Center for Movement Arts (Bengaluru). Tripura teaches on the diploma and certificate courses run by CMTAI in Pune, Delhi and Bangalore and was on the teaching faculty of M.A Performance studies, Ambedkar University, Delhi.

- **Reetu Jain**

Reetu Jain is Co-Founder of [Creative Movement Therapy Association of India \(CMTAI\)](#), a Creative Movement Therapy Facilitator, a dancer/choreographer, and visiting faculty with Ashoka University and Ambedkar University. She is originally from Texas and has been living in India for the past ten years.



As a Creative Movement Therapy Facilitator, Reetu has primarily worked with underserved adolescents and individuals who identify as transgender (*hijra*) by creating open and safe platforms for self-discovery, dialogue, and expression. Reetu has facilitated CMT workshops at NGOs, educational institutions, and corporates across India and most recently presented a virtual talk for Womeninnovator on “[Therapeutic Movement and Dance Movement Therapy for Mental Health and Well-being in Covid-19 Times.](#)”

Reetu is currently pursuing her PhD in Expressive Therapies at Lesley University, USA, with her research focus on exploring the role of the arts in sexual violence prevention programs working with youth in India. She defended a pilot study investigating experts’ views and experiences on the potential of the arts in youth sexual violence prevention efforts. Reetu was selected as an [ADTA Talks](#)’ speaker at the American Dance Therapy Association’s 50th Annual Conference and has represented India and the field of creative movement therapy at various forums, including the DaDaFest International Congress in the UK in 2016, the Ananta Centre (formerly Aspen Institute India) leadership conference on ending sexual violence in 2014, and the Harvard South Asia Institute “Gender Justice, Criminal Law, and Curricular Reforms” conference in 2013.

- **Sneha Shashidhara**

Sneha is currently with CSBC as a researcher interested in mechanisms of the brain underlying higher order cognition and decision making, with an added social perspective. She completed her PhD at Cambridge UK, studying the multiple demand network in the brain, that is active in different demands, be it language, memory, math etc and handles many types of task difficulty. Prior to that, she did her Masters in Neuroscience at Goettingen, Germany.



Courses

The Psychology Department offers a range of courses structured around three tiers: Fundamental Courses, Core Domain Courses, and Electives. These courses give students both the breadth of the discipline and sufficient depth for students who wish to have a more narrow specialization within a domain. Note that some courses have prerequisites (courses that must be taken before enrolling in a particular course); co-requisites (courses that must be taken concurrently); and preclusions (courses that have sufficiently similar emphasis and must not be taken together with that course). Most courses are worth 4 credits (unless otherwise stated), and the workload for each 4-credit course is about 10 hours per week.

Monsoon 2020:

1. PSY-1001 Introduction to Psychology
2. PSY-1003 Thinking Like A Psychologist
3. PSY-2001 Statistics and Research Methods- I
4. PSY-2002 Statistics and Research Methods- II
5. PSY-2011/ BIO-2103 Introduction to Neuroscience
6. PSY-2031 Developmental Psychology
7. PSY-2041 Clinical Psychology
8. PSY-2051 Social Psychology
9. PSY-3062 Gender, Feminism and Mental Health
10. PSY-3047 Psychotherapy | Counselling Psychology
11. PSY-3061 Gender and Mental Health
12. PSY-3082 Qualitative Research Methods
13. PSY-3100 Seminar Series in Psychology
14. PSY-3121 Empirical basis of Cognition
15. PSY-3097 Independent Study Module
16. PSY-3099 Independent Study Module II
17. PSY-4087 Advanced Independent Study Module
18. PSY-4070 Internship in Psychology Instruction
19. PSY-6001 Graduate Research Methods
20. PSY-2021 Cognitive Psychology
21. PSY-3141/ MS-3210 Communication Theory & Behavioral Change
22. PSY-3101/ BIO-3501 Biostatistics and Bioinformatics
23. PSY-3151/ SOA-321 Anthropology of Mental Health

Spring 2021:

1. PSY-1001 Introduction to Psychology
2. PSY-1003 Thinking Like A Psychologist
3. PSY-2001 Statistics and Research Methods- I
4. PSY-2002 Statistics and Research Methods- II
5. PSY-2021 Cognitive Psychology
6. PSY-2031 Developmental Psychology
7. PSY-2041 Clinical Psychology
8. PSY-2051 Social Psychology
9. PSY-3011 Advanced Neuroscience

CONFIDENTIAL

10. PSY-3035 Music and Cognition
11. PSY-3036 Cognitive Neuroscience: A Clinical Perspective
12. PSY-3046 Creative Movement Therapy
13. PSY-3047 Psychotherapy
14. PSY-3082 Qualitative Research Methods
15. PSY-4041 Helping skills
16. PSY-3097 Independent Study Module
17. PSY-3099 Independent Study Module II
18. PSY-4087 Advanced Independent Study Module
19. PSY-4087 Advanced Independent Study Module
20. PSY-4070 Internship in Psychology Instruction
21. PSY-4087 Advanced Independent Study Module
22. PSY-4087 Advanced Independent Study Module
23. PSY-4070 Internship in Psychology Instruction
24. PSY-2376/ CS-2376 Data Mining and Warehousing
25. PSY-3057/ ECO-3620 Behavioral Economics
26. PSY-3141/ MS-3210 Communication Theory & Behavioral Change
27. PSY-3153/ MS-3215 Content Analysis and Communication Research Method

Course Levels and Pre-Requisites:

The two 1000-Level Courses are Gateway Courses and are typically prerequisites for taking higher level courses. It is strongly recommended that students take a Gateway course and SRM-I as soon as possible. Beyond this, the department does not impose a sequence in which to take core courses. Note though that some courses have prerequisites (courses that must be taken before enrolling in a particular course); co-requisites (courses that must be taken concurrently, that complement each other's knowledge base if taken together); and preclusions (courses that have sufficiently similar emphasis and must not be taken together with that course). Often, elective courses will have a gateway course, one or more statistics courses and one core domain course as prerequisites.

Note that the first digit of the course code specifies whether the course is at an introductory level to be taken in the second or third semester (1000), a core course level to be taken in the third or fourth semester (2000), a higher level elective (3000), a course specifically envisioned for fourth year ASP students (4000), or a specific graduate level course (6000). Some courses that are listed both at undergraduate and graduate level cover the same material but offer advanced assignments for graduate students. While the third and fourth digits just track and group multiple courses in various subdomains, the second digit of the course code specifies the overall course domain:

0 Introduction, Statistics or Methodology domain

1 Bio domain

2 Cognitive domain

3 Developmental domain

4 Clinical domain

5 Social domain

6 Electives offered by visiting faculty

7 Instructional electives

8 Methodology electives

9 Lab or research module

Curriculum structure

The structure of the psychology curriculum resembles a pyramid, with Fundamentals (Gateway, Statistics and Research Methodology) at the top-tier, Core Domains (Biological, Cognitive, Developmental, Clinical, and Social Psychology) in the middle-tier, and Electives at the lower-tier. Students are encouraged to complete their Fundamentals and Core Domains as early as possible, because many of these are prerequisites for upper-level electives. For more information, please [click here](#).

Courses we offer:

Gateway courses

PSY 1001 Introduction to Psychology

This course introduces psychology as an empirical, behavioral science. It considers the approaches different psychologists take to describe and explain behavior. It covers a broad range of topics, including how animals learn, how personality develops and influences functioning, how the nervous system is structured and how knowledge of neuroscience may inform a neurodiverse understanding of mental variation, how people acquire, remember and process information, how psychopathology is diagnosed and treated, how children and adults develop, and how people behave in groups and think about social environments.

Prerequisites: None.

Offered: Recommended for Semester 2, but also offered every Monsoon and Spring

PSY 1003 Thinking like a Psychologist

This course is offered only to students who have studied psychology at a pre-college level and can then substitute for PSY 1001. The focus of the course is not on understanding introductory psychological concepts – we will barely cover any – but on building the skills necessary to think critically and scientifically like a psychologist.

Prerequisites: No Ashoka courses, but Psychology in Class 11, 12 in CBSC, IB and ISC boards.

Offered: Recommended for Semester 2, but also offered every Monsoon and Spring.

PSY 2001 Statistics & Research Methodology I

The primary focus of this course is mastering basic statistical concepts and reasoning. In the process, students will learn characteristics of different types of research, and how to think critically about statistics. The course also includes a practical component where students learn how to use statistical software to analyse existing datasets (secondary data analysis). Students are advised to take this course as soon as possible.

Prerequisites: None.

Preclusion: Statistics for Economists (Economics Department)/ Probability and Statistics (Mathematics Department).

Offered: Recommended for Semester 2, but also offered every Monsoon and Spring

PSY 2002 Statistics & Research Methodology II

The primary focus of this course is on mastering different research methods and research designs, with more in-depth learning of statistical thinking. Students will embark on an empirical project where they will devise testable hypotheses, design a study to collect primary data, and then analyze, interpret, and present their findings. Students are advised to take this course as soon as possible.

Prerequisites: Statistics & Research Methodology I (Psychology Dept), or Statistics for Economics (Economics Dept), Probability & Statistics (Math Dept)

Offered: Usually in Semester 2, but also offered every Monsoon and Spring

Core courses

PSY 2011/ BIO 2103 Introduction to Neuroscience

This course provides an introduction to the relationship between brain and behaviour. The focus will be on understanding how behaviour is produced by the brain. The course seeks to answer key questions about how neurons produce behaviour, how the human brain is organized and how the brain processes information.

Prerequisites: None

Offered: Every Monsoon

PSY 2021 Cognitive Psychology

In this course, students will consider cognition, a subtopic within the field of psychology. The specific emphasis of cognition is on a scientific consideration of how people think and how they process information. We will examine current models in cognitive psychology from a theoretical perspective as well as the research methods that allow us to make accurate inferences about the workings of the mind. Topics will include perception, attention, memory, imagery, language, comprehension, problem solving, and decision-making.

Prerequisites: Introduction to Psychology

Offered: Every Monsoon and Spring

PSY 2031 Developmental Psychology

This course reviews the fundamentals of developmental psychology, a field of study devoted to understanding both the continuity and change that makes up human growth throughout the lifespan. Students will gain exposure to a range of developmental psychology theories and learn how these are applied to developmental milestones across life-stages.

Prerequisites: Introduction to Psychology

Offered: Every Monsoon and Spring

PSY 2041 Clinical Psychology

This module introduces the most common self reported mental health problems such anxiety, depression, eating disorders, behavioural problems, attention deficits, learning disabilities, schizophrenia, personality disorders, sexual adjustment, substance abuse, suicide, and dementia. The course focuses on developing a holistic and nuanced understanding of these mental health issues, with a critical understanding of diagnosis and pathology.

Prerequisites: Introduction to Psychology

Offered: Every Monsoon and Spring

PSY 2051 Social Psychology

This course explores the scientific nature of social influence and interaction, covering topics such as social judgment, self-concept, attitudes, conformity, prejudice, and interpersonal relationships. We will also pay particular attention to the use of empirical evidence from which we build theories of social behaviour.

Prerequisites: Introduction to Psychology

Offered: Every Monsoon and Spring

Elective courses in 2020-2021

PSY 3011 Advanced Topics in Neuroscience

This course allow students to explore the neural processes that produce various aspects of cognition and behavior, such as sensation, motor control, communication, creativity, navigation, decision making, learning and memory. The goal of this class is for students to explore various topics in neuroscience that give one a sense of the possible framework of computation through electrical signaling by wet, messy, living systems. We discuss the strengths and limitations of various methods by which inferences about the neural basis of cognition are made, by reading and evaluating primary scientific material.

Prerequisites: Introduction to Neuroscience

Offered: Every other Spring

PSY 3082 Qualitative research methodology

Although quantitative methods feature heavily in modern psychological research, qualitative data is also useful in many ways; sometimes it is even indispensable when studying certain phenomena. But qualitative research methodology is not just about asking people what their opinions or feelings are about a particular issue. This course trains students to extract information from qualitative data to yield psychological insights.

Prerequisites: Statistics and Research Methods II; completed at least 3 out of 5 core domains

PSY 4041 Helping Skills

This course focuses on effective helping skills. Students learn about the effectiveness of helping skills by (i) learning about the theory and research on helping skills and (ii) practicing helping skills with each other.

Prerequisites: Introduction to Counseling

PSY 3099 Independent Study Module

The Independent Study Module (ISM) allows students to delve more deeply into research, either assisting an instructor on a specific research agenda, or in some cases, charting their own research agenda. Students must seek out an instructor in the department and work out a concrete plan with the instructor before signing up for the course. Students may do only one ISM at level-3000.

Prerequisites: Introduction to Psychology; Statistics and Research Methods I; with consent of instructor; subject to mutual interest between student and faculty

PSY 4089 Advanced Independent Study Module

The advanced Independent Study Module (ISM) is for UG4 students who are not doing an honors thesis, yet want further exposure beyond the initial PSY 3099 ISM which they have already taken. Students must seek out an instructor in the department and work out a concrete plan with the instructor before signing up for the course.

Prerequisites: Introduction to Psychology; Statistics and Research Methods I and II; PSY 3099; subject to mutual interest between student and faculty

Preclusion: PSY 4099

PSY 4070 Internship in Psychology Instruction

This instructional internship exposes students to the teaching of psychology where undergraduates serve as teaching assistants (UGTAs) in level- 1000 or -2000 courses of their choice, subject to mutual interest with the instructor and programme needs. Through this internship, students gain a deeper understanding of the subject matter, gain insights into how courses are planned, and learn how to communicate their subject matter in ways that will lead to successful learning. Only one student will be accepted per section of a course, per enrollment of 30. Interested interns should read the guide and syllabus for PSY 4070.

Prerequisites: UG4 psychology major; be in good GPA standing; possess the necessary psychological traits (e.g., emotional stability, motivation, positive learning attitude).

PSY 4098 Honours Research Seminar

This is an 8-credit preparatory course for PSY 4099 Honours Thesis. Students will learn the process of research from their advisor and from one another. At the end of the course, students will produce and defend their research proposals, and critique other students' proposal.

Prerequisites: Completed 12 psychology courses; only for fourth-year students with at least 3.0 GPA, or with consent of a prospective advisor; students must have already secured an honours thesis supervisor.

PSY 4099 Honours Thesis

This is an 8-credit capstone course where students will complete a piece of scholarly work over two semesters that contributes substantially to the knowledge and/or application of the discipline. In addition, students are expected to defend their work in front of peers and members of their thesis committee. Students must seek out an instructor in the department and work out a concrete plan with the instructor before first week of the course. Students should read the guidelines for PSY 4098 and PSY 4099 here.

Prerequisites: Completed 12 psychology courses; only for fourth-year students with at least 3.0 GPA, or with consent of a prospective advisor; PSY 4098 Honours Research Seminar; subject to mutual interest between student and faculty.

Elective courses offered in other years:

PSY 3012 Evolutionary Cognition

What is cognition? How has it evolved? What cognitive abilities do animals possess? Are they similar to those found in humans? What narratives about the evolution of behaviour are scientifically grounded? This course provides a critical review of various theories of the

evolution of cognition and training on how to review the standards of evidence behind various claims.

Prerequisites: None, but students are advised to have taken Introduction to Neuroscience

Offered: Every other Spring

PSY 3032 Atypical Development

This course examines the psychological, biological, environmental, and cultural influences on the development of atypical infants and children. Specifically the emphasis is to improve developmental outcomes and study the implications of atypical development for intervention and education, for family adjustment, and for improving quality of life. Research studies that provide empirical evidence will also be reviewed to expand the scope of understanding atypical patterns of development.

Prerequisites: Developmental Psychology; Statistics & Research Methodology II

PSY 3033 Psychology of Language

Language is so crucial that a lot happens when we speak. Our ability to comprehend and express our ideas or thoughts is taken for granted every day, yet what is something that is so special and amazing about any language that comes naturally to all of us and how does it work?

Prerequisites: Developmental Psychology; Statistics & Research Methodology II

PSY 3034 Embodied Cognition

This course will involve contrasting approaches to understanding cognition, helping us understand how cognitive agents interact with a complex environment, and how aspects of the environment contribute to cognitive processes.

Prerequisites: Cognitive Psychology; Developmental Psychology; Statistics & Research Methodology II

PSY 3041 Psychopathology

This course will focus on understanding and analyzing the biological basis of psychological disorders. The course will be a mix of didactic lectures and problem-based learning sessions. Students will build upon their knowledge from the clinical psychology class to delve deeper into the subtleties of psychological disorders, including analyzing patient case studies.

Prerequisites: Clinical Psychology; Statistics and Research Methodology II

PSY 3042 Introduction to Counseling

This course is designed to provide the student with an overview of counseling psychology as a profession. It will introduce the student to the scientist/practitioner model, and in so doing, define the subject matter of counseling psychology, the target population the counseling psychologist seeks to serve, and the technical tools professional counselors use during their practice.

Prerequisites: Introduction to Psychology; Statistics & Research Methodology I; Clinical Psychology

PSY 3043 Drugs and Behaviour

This course, with a focus on psychoactive drugs, will explore the neurotransmitter systems underlying abnormal psychology and behavior and how modern generation drugs alter

CONFIDENTIAL

neurotransmitter balance to putatively restore functionality and behavior. The course is designed to introduce pharmacological concepts for students without prior exposure to college level biology and build upon the knowledge from clinical psychology to explore psychopharmacology-based treatment approaches. The course material will heavily draw from primary literature and randomized clinical trials of import in the field.

Prerequisites: Introduction to Neuroscience; Clinical Psychology; Statistics & Research Methodology II

PSY 3044 Violence as a Human Behaviour

This course brings in materials pertaining to violence and aggression across the disciplines of neuroscience, evolutionary biology, sociology, psychology and political science. The course will first try to break violence down to its neurobiological roots, and then rebuild it using perspectives from behavior, sociocultural patterns and aggression. We will examine mob violence, violent crimes, violence against women and children, violence against ethnic minorities and “legitimized” violence.

Prerequisites: Introduction to Neuroscience; Statistics & Research Methodology II

PSY 3051 Behavioural Change

Humans sometimes behave in ways that are dysfunctional not only to themselves, but to those around them. This course brings together insights from social psychology and other allied disciplines to address the promises, pitfalls, and challenges psychology can be used to address real-life problems in climate change, poverty, health, environment, public policy, and so on.

Prerequisites: Social Psychology; Statistics & Research Methodology II

PSY 3052 Emotion

This course examines the nature of emotions from various perspectives (e.g., cognitive, social, cultural, and biological perspectives). The emphasis is on developing a nuanced understanding on how emotions affect behavior, and how behaviors affect emotions. Classic emotion research will be revisited, as well as the introduction of current advances in emotion research.

Prerequisites: Social Psychology; Statistics & Research Methodology II

PSY 3053 Cultural Psychology

This course focuses on human cognitions and behaviors that are affected by our cultural differences and similarities across cultures. We will think about and understand how these processes occur and are shaped, and also question whether these characteristics are fundamental, and to what extent they are plastic.

Prerequisites: Cognitive Psychology; Social Psychology; Statistics & Research Methodology II

PSY 3054 Social Cognition

This course focuses on the cognitive mechanisms underpinning many forms of social behaviour. How do individuals perceive and reason about information related to other people and their environment? How much of the environment affects our behaviour -- and are these influences necessarily conscious?

Prerequisites: Cognitive Psychology; Social Psychology; Statistics & Research Methodology II

PSY 3055 Intergroup relations

Humans are social beings, and therefore, often identify with groups. These groups can be based on various social identities (e.g., religion, gender, sexual orientation, etc.) or they can be minimal groups (e.g., experimentally-assigned groups based on color of one's hat). This course introduces you to the psychological processes involved in how individuals, who are members of groups, think, feel, and behave towards other group members.

Prerequisites: Social Psychology; Statistics & Research Methodology II

PSY 3081 Psychological testing and assessment

Psychological constructs such as workplace motivation, intelligence, narcissism, conscientiousness, etc., are often abstract. To be able to study these topics, one must be able to translate abstract constructs into concrete operationalizations. This course introduces you to the fundamentals of measuring psychological constructs, selecting test instruments, and the ethics of psychological assessments.

Prerequisites: Statistics and Research Methods II; completed at least 3 out of 5 core domains

Undergraduate student section: Majors, minors, ASP

Requirements for Major

Each student must complete 12 courses towards the major (12 x 4 = 48 credits). To complete a major in Psychology, one **must take the following 8 required courses (8 x 4 = 32 credits) and any 4 electives (4 x 4 = 16 credits):**

- PSY101: Introduction to Psychology/Thinking Like a Psychologist (**Gateway Courses**)
- PSY201: Statistics and Research Methods- I (**Statistical Course**)
- PSY 202: Statistics and Research Methods- II (**Statistical Course**)
- PSY211: Introduction to Neuroscience (**Core Domain Course**)
- PSY221: Cognitive Psychology (**Core Domain Course**)
- PSY231: Developmental Psychology (**Core Domain Course**)
- PSY241: Social Psychology (**Core Domain Course**)
- PSY251: Clinical Psychology (**Core Domain Course**)

Students can also apply up to four 4-credit courses taken at accredited universities elsewhere (i.e., summer abroad or exchange programmes) towards the major requirements, contingent on the formal approval of Ashoka University and the Psychology Department.

Other than cross-listed core courses or cross-listed elective courses offered by the Psychology department, students are not encouraged to fill up on more than 3 electives offered by other departments and accepted for cross-listing by the Psychology department.

Curriculum structure

The structure of the psychology curriculum resembles a pyramid, with Fundamentals (Gateway, Statistics and Research Methodology) at the top-tier, Core Domains (Biological, Cognitive, Developmental, Clinical, and Social Psychology) in the middle-tier, and Electives at the

lower-tier. Students are encouraged to complete their Fundamentals and Core Domains as early as possible, because many of these are prerequisites for upper-level electives. For more information, please click [here](#).

Requirements for Minor

Each student must complete 6 courses towards the minor (6 x 4 = 24 credits). The student **must take the following three courses (3 x 4 = 12 credits):**

- PSY1001/PSY1003: Introduction to Psychology/Thinking Like a Psychologist
- PSY2001: Statistics and Research Methods- I
- PSY 2002: Statistics and Research Methods- II

The student **may take either 2 or 3 of any of the following courses (2 x 4 = 8 credits OR 3 x 4 = 12 credits):**

- PSY2011: Introduction to Neuroscience (group A)
- PSY2021: Cognitive Psychology (group A)
- PSY2031: Developmental Psychology (group B)
- PSY2041: Social Psychology (group B)
- PSY2051: Clinical Psychology (group B)

Students are encouraged to ensure they take at least one course from Group A, and at least one course from Group B.

The student **may take 1 elective course, worth 4 credits.**

Students who are exempted from Statistics and Research Methodology I (e.g., those who have taken EC102 – Statistics for Economists; no other course is currently considered for exemption from SRM1) may take only 5 courses for their minor instead of 6 courses. Independent Study Modules do not count towards the minor.

Students should note that it may be difficult to complete a minor within three years because (i) the psychology courses offered may clash with their major courses; (ii) some courses require prerequisites; and (iii) some courses are offered only once a year. Note also that the courses specified in the above descriptions are tentative; exact course listings will depend on available faculty and their actual offerings.

Requirements for Concentration

The psychology department does not offer a program for a concentration in Psychology.

Undergraduate exchange programs/ Summer abroad programs:

Psychology majors intending to go for a summer abroad or semester-long exchange programmes should be aware that most upper-level psychology modules have prerequisites, which may not be explicitly mentioned in the host universities' webpages. In general, students should clear as many Fundamental and Core Domain courses before going for a summer or semester abroad. For courses taken at host institutions abroad to count towards their Psychology degree at Ashoka, students must fill a credit transfer form stating the courses they plan to take at the host institution and send this along with the detailed course syllabi and course timings to the HoD, copying the professors who offer the equivalent course at Ashoka. Ashoka University matches the number of transfer credits with the number of contact hours, subjected to OAA's regulations for the

maximum number of credits allowed to be transferred throughout a student's candidature. A typical course at Ashoka is 4 credits (13 weeks x 3 hrs = 39 contact hours). The final decision on whether credits amassed at a summer/semester institution can be transferred to your degree requirements at Ashoka will be of the HoD. Students should follow this protocol and read the frequently asked questions here first before seeking advice from the Program Coordinator during their planning stages.

Independent Study Modules (PSY399):

Independent Study Modules (ISMs) are research modules. In general, students can do theoretical research (write review papers) or empirical research (e.g., conducting experiments), or both (e.g., propose a topic, run an experiment, and write results). Different professors have different ways of conducting an ISM. Enrolling for one requires the student to consult the relevant faculty and register one's interest. ISMs are not necessarily pre-defined courses: while some faculty may offer a set of ISMs that align with their research, students may also propose novel ISMs to a faculty member. The decision to enroll a student in an ISM is ultimately that of the faculty member conducting the ISM.

Only two courses/8 credits worth of Independent Study Module(s) can be taken by each student during their three-year UG Psychology program. 4th years/ASPs can take two courses/8 credits worth of Advanced ISMs that ideally build upon past research experience to the satisfaction of the faculty with whom you take it.

Because an ISM is a research module, it will help students gain research experience. Research experience is very important if you want to go on to masters/PhD degree. But even if you do not want to do this, and you are just simply curious at how knowledge is produced, or you want to try your hands at producing new knowledge instead of absorbing knowledge in a classroom, doing an ISM is a useful experience. In some sense, every theory that you know now stems from a research idea, which then turns into an exercise to find empirical evidence to prove/disprove the hypothesis.

Undergraduate Teaching Assistantships:

The Psychology Department offers the Internship in Psychology Instruction course (PSY 4070) to students in their ASP/4th year at Ashoka. Students can only take PSY 4070 once in their time at Ashoka, with rare exceptions during years with a small UGTA cohort.

In order to enroll for the same, students must either fill in the form that is circulated by the TA/TF coordinator Dr. Maganti, or write to faculty that they wish to TA for and express their interest. Selection for the role is the prerogative of the faculty member and the Department does not have a set criteria for the selection of UGTAs.

This course prepares senior undergraduate students for college teaching. By now you should have a decent mastery of psychological concepts. How did you attain this mastery? Chances are your mastery was a result of the effort you put in as a student and the didactics used by your instructor. How does one become a good psychology instructor? And how does one learn? In this course, students will be trained in basic pedagogy, familiarize themselves with education and

CONFIDENTIAL

pedagogical issues surrounding higher education, culminating in giving two classes (Basic or Core Domain courses) as an instructor.

Course schedule

Week	Task	Graded?	Prep time
-2	Selected students (now known as <i>interns</i>) will read two books by Ken Bain: (i) <i>What the best college teachers do</i> ; (ii) <i>What the best college students do</i> . Both books are available in the Ashoka Library. Interns are matched to instructors.	No	30 hrs
2	Interns will submit an Expectation Statement to their instructor, focusing on the kind of teacher they aspire to become. In addition, they will read Carnegie Mellon University's "Obligations and expectations for undergraduate teaching assistants", Available at https://www.cmu.edu/teaching/resources/PublicationsArchives/UGT_A_TAs-v2.pdf .	10%	4 hrs
2-13	Interns will assist in course management (e.g., class preparation, information dissemination, taking attendance, review exam questions, grading assignments, proctoring exams, etc.) and classroom instruction with supervision (e.g., assisting classroom discussions, conduct review sessions, etc.).	10%	4 hrs × 13
P1	Interns will conduct their first graded practicum. Feedback will be provided by their instructor during preparation and at the end of the practicum.	30%	20 hrs
P2	Interns will conduct their second graded practicum. Feedback will be provided by their instructor during preparation and at the end of the practicum.	30%	20 hrs
14	Interns will submit a reflection piece about: (i) their teaching experience, and (ii) suggesting improvements for the course and their own teaching. These two will be submitted to the Programme Coordinator and the instructor.	20%	10 hrs
Total for 13 weeks		100%	≈136 hrs

Course objectives

At the end of the course, students will:

- Be confident and effective instructors;
- Understand basic issues in the philosophy of education and pedagogy;
- Learn how to communicate concepts in ways that students will learn;
- Learn course and classroom management techniques.

Assessment components

- Expectation Statement: 10%
- Practicum 1: 30%
- Practicum 2: 30%
- Reflection report: 20%
- Course management: 10%

Requirements for an Advanced Major for Ashoka Scholars' Programme (4th Year):

There are two options if you wish to do an Advanced major— **Capstone Thesis for Advanced Major OR Upper Level Electives for Advanced Major**. In both cases, **a minimum of 16 credits must be amassed** during the ASP year.

1. **Upper Level Electives for Advanced Major:** Students can enroll in higher level electives such as the Internship in Psychology Instruction and Advanced Independent Study Modules. 4 such courses of 4 credits each ($4 \times 4 = 16$) must be completed in the ASP year in order to graduate with an Advanced Major, and up to two more such courses can also be taken to count towards the Advanced Major.
2. **Capstone Thesis for Advanced Major:** Students must enroll for the Honors Research Seminar (**worth 8 credits**) during their first semester of ASP and for the Honors Research Thesis (**worth 8 credits**) during their second semester of ASP. They can also take two additional Psychology electives (worth 8 credits in total) counting towards the advanced major. Students will only be approved to enrol for these courses if they are selected by the departmental process, which in turn is predicated on their having organized a plan to do so with the faculty advisor of choice, ideally after having already worked in their lab either informally or as an ISM. The department's faculty ASP coordinators (Dr. Avantika Bhatia and Dr. Rashmi Nair for 2020-2022) will send out a form eliciting interest in the capstone thesis in the sixth semester, and faculty will take a final call based on their existing agreements with students on jointly working towards a thesis.

Undergraduate capstone thesis details

An honours thesis is a capstone course where students will complete a piece of original scholarly work that contributes substantially to the knowledge and/or application of the discipline. Doing a thesis requires a substantial amount of commitment and time management skills. The workload is spread over two semesters, comprising two 8-credit courses, PSY 4998 Honours Research Seminar in the monsoon and PSY 4999 Honours Thesis in the spring. You should expect to spend no less than 20 hours per week per semester. PSY 4998 and PSY 4999 are taken as a package, although registrations begin formally in Jul/Aug for PSY 4998 and Dec/Jan for PSY 4999. It is not possible to do PSY 4999 without completing PSY 4998. It is, however, possible to exit the thesis “halfway”. That is, students have the option to not continue with PSY 4999 after they have completed PSY 4998 at the end of the Monsoon. In some cases, they may be advised not to continue with PSY 4999. In either case, students who do not continue with PSY 4999 have the option to do an (advanced) independent study module (PSY3099 or PSY4087).

Eligibility

The honors program is typically in the same field as the major subject of the student, hence the student must fulfil the OAA’s requirements of the advanced major. A minimum GPA of 3.0 is required. Exceptions may be considered by writing to the Programme Coordinator.

Composition of the thesis committee

Your thesis committee consists of two faculty members. One of them is your advisor; you should choose the second member (second reader) in consultation with your advisor. The role your second reader plays should ideally be discussed with them, as well as with your primary advisor, before confirming your second reader.

Grading

PSY 4998:

- Advisors’ assessment of your peer review = 10%
- Advisors’s assessment of student’s research progress = 30%
- Advisor’s assessment of student’s research proposal = 30%
- Second reader’s assessment of student’s research proposal = 30%

PSY 4999*:

- Advisor’s assessment = 30%
- Advisor’s assessment of student’s research proposal = 35%
- Second reader’s assessment of student’s research proposal = 35%

**Note:* Grades are not dependent on the statistical significance of your findings.

Timelines

The timeline for AY2018/2019, circulated to students, is given in the table below. This gives a rough guideline for subsequent years.

Time	Task
UG3 Spring	Begin planning the undergraduate thesis. Start thinking about their research projects and ideas now, if not earlier. Discuss ideas with prospective advisors. Confirm your thesis advisor as soon as possible.

CONFIDENTIAL

Summer between UG3 & UG4	Plan the thesis committee together with your advisor. Start focused reading geared towards developing the bibliography for their research work in collaboration with your advisor.
UG4 Monsoon Week 1	Monsoon UG4: Psych 498 (Honours Research Seminar) Register for PSY 498 with OAA Start planning and conducting research, collecting preliminary data Start working on the IRB application.
UG4 Monsoon Week 2	Finalize a thesis committee. Start working with the faculty advisor towards a thesis proposal document
UG4 Monsoon Week 3 Friday	Submit a first draft to your advisor with Introduction (background, hypothesis, research questions and rationale), Methods, and any supporting preliminary data. First draft must be written in APA style (6 th edition).
UG4 Monsoon Week 6 Sunday	If you are doing research with human subjects, file an IRB application online at the earliest after monsoon semester starts. Note that the approval time depends on the complexities of the ethical issues involved. Visit https://www.ashoka.edu.in/page/institution-review-board-39 for more details. Submit a final draft of the thesis proposal document to your advisor and committee member. Students who fail to submit by Week 6 Sunday will drop a grade.
UG4 Monsoon Week 7	You will also receive one of your peer's thesis proposal this week. Your task is to write a professional review of your peer's proposal. Your review may be shared with the peer whom you are reviewing, and as such you may request to be anonymous to the peer.
UG4 Monsoon Week 9 Monday	You will submit the review of your peer's work to your advisor.
UG4 Monsoon Week 9 (i.e., the week when we return from mid-sem break)	Colloquium of presentations of thesis proposals (15 min presentation + 10 min questions). This is open to the entire university and the participation of all intended psych majors is strongly encouraged. Questions may come from the committee members or anyone in the audience. You will receive the committee's feedback on the proposal framework, experimental design, analytic strategy, impact, etc. This colloquium is not graded.
UG4 Monsoon Week 11 Monday	Based on the feedback, you will submit a final proposal to your advisor and committee member. Your research progress will be evaluated throughout the semester.

Between Monsoon Week 12 and Spring Week 10: Data collection	
<p>***Note that in some fields, multiple studies are expected. Check with your advisor.***</p>	
<p>UG4 Spring Week 10</p>	<p>Spring UG4: PSY 499 Register for PSY 499 with OAA, if you haven't already done so. You should complete your data collection and analysis by this time, and submit a first draft of their final thesis. Note that writing a quality draft takes a long time, often with repeated revisions. Plan ahead.</p>
<p>UG4 Spring Week 12 Friday</p>	<p>Once your advisor provides feedback on this initial draft, you should revise your thesis and submit a second draft to all members of your thesis committee. This is the draft the committee will examine during the defense. This draft will not be graded but will help your committee members give better comments. Hence aim to submit a quality draft.</p>
<p>UG4 Spring Week 13 (date to be decided)</p>	<p>Thesis Defence Colloquium (approx. 30-40 mins; duration to be confirmed when the date approaches). This is open to the entire university and the participation of all intended psych majors. Questions may come from the committee members or anyone in the audience. Your committee members will give you feedback on the content and writing of the thesis.</p>
<p>UG4 Spring Week 14, Wednesday</p>	<p>Thesis Submission: Revise your thesis based on feedback from your committee. Note that a thesis is not merely the proposal you wrote last semester plus whatever work you have done this semester. Often you will need to substantially overhaul what you wrote in your proposal and re-conceptualize many issues. Hence leave enough time (about 1 month) to write and edit your work.</p> <p>Submit the following: One hard-bound thesis meant for the library's archive; Two soft-bound copies meant for grading by your committee members; A digital softcopy. You may wish to print additional hard- or soft-bound copies for your keepsake.</p> <p>You will drop a full letter grade for every day you submit late. Your committee members have a very tight timeline to submit grades to the OAA before your convocation and will hence appreciate your timeliness.</p>
<p>Congratulations on successfully completing a significant piece of scholarly work. Celebrate your achievements!</p>	

Frequently Asked Questions:

Q. Which Gateway course do I take— Introduction to Psychology or Thinking Like a Psychologist?

A. Doing Psychology in the 11th and 12th Grade (CBSE, ISC, IB, A Levels (Cambridge)) is a prerequisite to taking Thinking Like a Psychologist. If the student has not done Psychology in the 11th and 12th Grade, they must take Introduction to Psychology. If they have done Psychology in the 11th and 12th Grade, they can take either course, although there will be overlap between Introduction to Psychology and the material they have already covered in the 11th and 12th.

Q. Can SRM-I be waived off if I have done an equivalent statistics course from another department (for example, Statistics for Economics offered by the Economics Department)?

A. Yes, completing the courses mentioned below are usually sufficient to waive off SRM-I, but not SRM-II. Further, these courses are not counted in the credits amassed towards Psychology. Note that the following courses can not be counted towards a waiver for SRM1 starting from Spring 2021: Quantitative Research Methods offered by the Political Science Department, while the following can: Probability and Statistics (Mathematics Department), Statistics for Economics (Economics Department).

Q. I have completed Foundation Requirements specified by the Office of Academic Affairs for my batch but the number of courses differs from the previous handbook released by the Psychology department. Is that a problem with regard to me completing a major?

A. As long as you have satisfied the foundational and other requirements specified for your batch by the OAA, you just have to complete the major requirements specified above to get a Psychology major - these have not changed from batch to batch.

Q. Can I take X course despite not meeting prerequisites?

A. The prerequisites are there to ensure you won't have difficulty following the material. Students can get waivers by writing to the instructor of the course, but often students who get waivers later find the course prohibitively difficult.

Q. Would it be possible to increase the course-cap for X course?

A. This is entirely the call of the faculty who offer these electives; as department head I have already put in the request. If interest in a course vastly exceeds the cap, we can always consider hiring someone to teach an extra section. For this, the N category in the student tracker needs to exceed our planned sections, so this is where you should indicate interest or need to take a course long before the semester in which you plan to take it.

Q. Can X course be rescheduled?

A. The OAA does not permit rescheduling of courses after pre-registration begins. Requests for rescheduling may constitute a preference of a minority of students, and so there is no responsible way to respond to these requests. Before every semester we circulate a form to assess interest in these courses at

<https://docs.google.com/spreadsheets/d/1dRkMzB76xGWG27fIycO7ZvxqFAJzACI15M0V00GdMps/edit#gid=0>.

Q. Can X course offered by Y department be cross listed by Psychology?

A. The process for this is for the faculty offering X course to send the course syllabus to the Head of the Psychology department as well as any faculty who teaches an area of psychology adjacent to or similar to the material covered by course X. If the Psychology department finds the course to be methodologically in line with the scientific approach of the department and relevant to the study of behaviour, we could decide to cross-list it and give it a Psychology course code.

Q. I'm a first year prospective psychology major. Do I need to take SRM 1 along with Intro/Thinking like a Psychologist in my second semester?

A. If one wants to be able to access all the core courses in one's third semester without further barriers, one needs to take both these courses. However, one can always do them in the third semester, and most core courses in the fourth, and have the whole third year for finishing cores and taking electives - this makes scheduling harder, but it is not impossible - so do not panic if you don't do these courses in the second semester - there is enough wiggle room for being one semester behind, but not more.

Q. I am interested in doing a TAship/writing a thesis although I'm not in my fourth year as yet.

A. Applications for doing TAships and the Capstone Thesis are only open to ASPs. The procedure for applying for the former has been specified above and registration for the Capstone Thesis happens on the LMS after consultation with a faculty member who will act as thesis advisor. However, you can always prepare to do research with a faculty member with or without academic credit, starting as early as your first year.

Q. I do not understand how the university's grading will translate to my post-grad applications. Does the psychology department write a letter to explain how our grades compare to the scale used by another country? Also, will the psych department somehow explain what the grades really mean, as each course is graded differently?

A. Ashoka does provide letters explaining our transcript. Graduate schools know they get grades from a variety of course and teaching and grading styles from different liberal arts universities. This is why other things that directly convey student quality like research publications, essays, SOPs etc. matter so much in graduate school applications - they directly convey your skills to the reader, and letters of recommendation also convey a sense of your work ethic.

Q. Who should I contact in case I have further questions?

A. Your first step should be to check if your question has already been answered at [:https://docs.google.com/spreadsheets/d/1yltdQVQm30a57-kFJoYs3EFALR8qIyAt4qj9mAbzE4g/edit#gid=2005135146](https://docs.google.com/spreadsheets/d/1yltdQVQm30a57-kFJoYs3EFALR8qIyAt4qj9mAbzE4g/edit#gid=2005135146). If not, place the question on the FAQ at https://docs.google.com/forms/d/1SrAfpAUsCKt1Se_CZfrir9tO_T4TTQvbc9hIKJd1nJg/edit. You will get a reply within 24 hours, often right away. You can also use the FAQ to make any suggestions around courses you'd like the department to offer, events we could organize, better ways to organize departmental processes, etc. You can also write to the Psychology student

representatives Aadya Singh (aadya.singh_ug20@ashoka.edu.in), Maanya Saran (maanya.saran_ug21@ashoka.edu.in) and Nivedita Nandakumar (nivedita.nandakumar_ug20@ashoka.edu.in) or to Professor Bittu, the Psychology HoD (HOD Psychology <hod.psychology@ashoka.edu.in>).

MLS section

Ashoka University Master's in Liberal Studies (MLS) with a focus in Psychology (AY 2019-2020)

Introduction

The MLS program allows students to complete a piece of original scholarly work that contributes substantially to the knowledge and/or application of the discipline. Doing a thesis requires a substantial amount of research skills, commitment, and time management skills.

Composition of your thesis committee

Your thesis committee consists of two faculty members. One of them is your advisor; the other is your reader. The role of your advisor is to guide students regarding developing a clear research question, research design/methodology, analysis, and writing. Students are expected to schedule regular meetings with their advisors for tracking progress of the students. The role of your reader is to provide comments and evaluate your final proposal and the final thesis; they do not serve as advisors. In case the student wishes to change their advisor they must set up a joint meeting with the current advisor and the prospective advisor to discuss the shift.

In certain exceptional circumstances, it may be possible for the student to work with two advisors. The student needs to present the rationale for a second advisor prior to the start of the MLS year (before the course registration), and the petition needs to be approved by the Psychology Department Faculty. Once approved, the advisor and second advisor are expected to work together on the evaluation and supervision components.

Thesis Format

The thesis can be written in chapter format or manuscript format, after consultation with the advisor. Thesis may be no longer than 15,000 words, excluding references and appendices.

Grading

PSY (course number):

Advisor's assessment of your peer review = 10%

Advisor's assessment of student's research performance/progress = 30%

CONFIDENTIAL

Advisor's assessment of student's research proposal (see attached guidelines. Table 1) = 30%

Reader's assessment of student's research proposal (see attached guidelines. Table 1)= 30%

PSY(course number):

Advisor's assessment of student's research performance = 30%

Advisor's assessment of student's final thesis (see attached guidelines. Table 2) = 35%

Reader's assessment of student's research proposal (see attached guidelines. Table 2) = 35%

**Note: Your grade is not dependent on the statistical significance of your findings.*

The evaluation of research performance by the advisor might include aspects such as the student's work ethic, independence in pursuing the project, perseverance, being proactive, timeliness and adherence to deadlines.

Research Practicum: 2 credits i.e. 60 hours (Monsoon) + 2 credits i.e. 60 hours (Spring)=4 credits (120 hours)

- 1) The aim of the Research practicum is to help students explore research that is being undertaken by the department.
- 2) Students are advised to approach faculty and assist them in their research.
- 3) In every semester, students are required to complete 60 hours of work.

Teaching Practicum Requirements: 2 credits (Monsoon) + 2 credits (Spring)=4 credits

1. Students are required to assist their advisors/ another professor from the department as a teaching assistant during each semester.
2. Teaching Practicum credits can be obtained in multiple ways depending on the educational background of the student.
 - i) Those students who have a psychology background are eligible to assist professors in core and introductory UG courses upon prior approval.
 - ii) Students who do not have a psychology background are required to approach the head of department and their advisor to discuss what UG courses they would be eligible to assist for.
 - iii) Students can also gain teaching practicum credits by applying for Teaching Assistantship in YIF PG courses and get the credits converted on OAA approval.

Other responsibilities

As per department needs, students are required to assist in

- i) Administrative work involving organising department activities, talks, seminars
- ii) Attend research meetings
- iii) Work with PhD/ASP students

MLS Timeline

Time	Task
YIF 8th Semester	Begin planning the MLS thesis. Start thinking about their research projects and ideas now, if not earlier. Discuss ideas with prospective advisors. MLS applications will open by Apr (date) and will close on Apr (date). Students will be asked for their topic of interest, research question, methodology, as well as to write to OAA and the potential advisor. By May (date), successful applicants will be notified about their advisor and reader.
Summer between YIF & MLS	<ol style="list-style-type: none"> 1. Start focused reading geared towards developing the bibliography for their research work in collaboration with your advisor. 2. Develop a clear research question with a strong rationale before the Monsoon semester begins.
MLS Monsoon Week 1	<p>Monsoon MLS: Research Methodology</p> <ol style="list-style-type: none"> 1. Start working with your advisor towards a feasible thesis proposal document, that you complete within the defined timeline. <p>Monsoon MLS: Research Practicum</p> <ol style="list-style-type: none"> 1. Discuss the research practicum expectations with a faculty. You may choose to assist any faculty in the department of Psychology. For 2 credits you are required to put in 60 hours of work.
MLS Monsoon Week 2	
MLS Monsoon Week 6 Friday	<ol style="list-style-type: none"> 1. Submit a first draft to your advisor with Introduction (background, hypothesis, research questions and rationale), Methods, and any supporting preliminary data. First draft must be written in APA style (7th edition). 2. Start working on the IRB application. 3. If you are doing research with human subjects, file an IRB application online at the earliest after monsoon semester starts. Note that the approval time depends on the complexities of the ethical issues involved. Visit https://www.ashoka.edu.in/page/institution-review-board-39 for more details.
MLS Monsoon Week 7	<ol style="list-style-type: none"> 1. You will also receive one of your peer's thesis proposal this week. Your task is to write a professional review of your peer's proposal. Your review may be shared with the peer whom you are reviewing, and as such you may request to be anonymous to the peer. 2. Submit your IRB application

MLS Monsoon Week 8 Friday	You will submit the review of your peer's work to your advisor.
MLS Monsoon Week 9	Revise thesis proposal based on advisor feedback.
MLS Monsoon Week 12 (i.e., the week when we return from mid-sem break)	Colloquium of presentations of thesis proposals (15 min presentation + 10 min questions). This is open to the entire university and the participation of all intended psych majors is strongly encouraged. Questions may come from the committee members or anyone in the audience. You will receive the committee's feedback on the proposal framework, experimental design, analytic strategy, impact, etc. This colloquium is not graded.
MLS Monsoon Week 13 Friday	Based on the feedback, you will submit a final proposal to your advisor and reader. Your research progress will be evaluated throughout the semester.
<p>Winter break: Data collection [You are expected to have completed the bulk of your data collection by the start of Spring semester]. Exceptions may be made by advisors.</p> <p>***Note that in some fields, multiple studies are expected. Check with your advisor.***</p>	
MLS Spring Week 1-5 Feb 23	<ol style="list-style-type: none"> 1. Register for Research Methodology (course number) with OAA, if you haven't already done so. 2. Discuss your analysis plan with your advisor. You should have completed your data collection by this time
MLS Spring Mar 28	Finish data analysis
MLS Spring May 30	Submit a first draft of your final thesis. Note that writing a quality draft takes a long time, often with repeated revisions. Plan ahead.

<p>MLS Spring June 12</p>	<p>Once your advisor provides feedback on this initial draft, you should revise your thesis and submit a final draft to your advisor and reader. This draft will not be graded but will help your committee members give better comments during the defense. Hence aim to submit a quality draft.</p> <p>Thesis Submission: Revise your thesis based on feedback from your committee. Note that a thesis is not merely the proposal you wrote last semester plus whatever work you have done this semester. Often you will need to substantially overhaul what you wrote in your proposal and re-conceptualize many issues. Hence leave enough time to write and edit your work.</p> <p>Submit the following:</p> <ul style="list-style-type: none"> • One hard-bound thesis meant for the library’s archive; • Two soft-bound copies meant for grading by your committee members; • A digital softcopy. <p>You may wish to print additional hard- or soft-bound copies for your keepsake.</p>
<p>MLS Spring June 17</p>	<p>Grading</p>
<p>MLS Spring June 26</p>	<p>Final grades to be sent to OAA.</p>
<p style="text-align: center;">Congratulations on successfully completing a significant piece of scholarly work. Celebrate your achievements!</p>	

PhD section

Psychology PhD Program Student Handbook

The PhD programme trains the next generation of rigorous, confident, responsible, and competent scholars who will address important problems, problems where the answer matters to science in particular, or to humanity in general (Medawar, 1979, *Advice to a Young Scientist*).

Accepted students are expected to commit full-time to their PhD studies. They are not allowed to take on paid jobs outside their studies, unless it can be demonstrated that these jobs contribute to their research. They are expected to spend no less than 40 hours a week, for 51 weeks annually. Candidates should know that it is not uncommon to spend 70 hours a week working towards their degree.

Vision and Mission statement

The Psychology PhD program at Ashoka University wishes to train a generation of psychologists from diverse backgrounds, irrespective of gender, caste, creed, orientation or religion. *We expressly seek individuals from marginalized groups and communities to be included in our program.* Our guiding principles are founded on imparting rigorous scientific training and building cross cultural awareness to address relevant psychological research problems. We will stress holistic development of our trainees into responsible scholars who are methodologically robust and ethically sound, and adept at principles of praxis. We want the graduates of this program to be well rounded individuals who practice and promote the discipline of psychology with meaningfulness to science and humanity.

General Structure of the PhD Program:

The PhD program will include academic and research training as well as ethical and career development training. The first two years (one year, in case of M.Phil./ M.Tech. entrants) will be heavily tilted to coursework and professional development and career planning workshops. **Students need a minimum of 24 coursework credits to advance to PhD candidacy in year 3. To maintain good academic standing in order to receive your fellowship, all PhD students are required to maintain a minimum GPA of 7.5 (i.e. A minimum grade of B- or above) for all coursework.**

From third year onwards, gradually the research components will start to predominate, and years 4 and 5 will be more or less research centric.

Three activities will be suggested for all PhD students through their tenure at the Department of Psychology at Ashoka University.

1. **Psychology Journal Club:** Every week a student will present a journal article. Attendance is mandatory for all PhD students. Senior students will present in the earlier part of the academic year for the newer entrants to learn from their peers

2. **Graduate research seminar in Psychology:** Every week two students will present their own research in front of the department. Attendance is mandatory for all PhD students and all faculty members are encouraged to attend the weekly GRS
3. **Teaching assistantships:** Each student will serve as graduate TAs in a course in consultation with the thesis advisor every semester starting from the beginning of second year. The particular arrangements will be worked out by the advisor and the department on a case by case basis.
4. **Individual Development Plan(IDP):** Every year, starting from the first year, students will submit an individual development plan to the PhD coordinator and the advisor by **October 1 of every academic year**. This will serve as a roadmap to the upcoming year for the student, and will be reviewed as part of their annual progress review. Further resources on how to think about an IDP is available online and some guidelines are provided below. The students will receive more guidance on this as they enroll in the program

Duration of the PhD program: For candidates with M.Phil or M. Tech, the duration of the PhD Fellowship is 4 years. For every other entrant, the duration of the PhD fellowship is 5 years. The PhD curriculum has been developed within this framework.

Major Milestones in the PhD program:

- For candidates with M.Phil or M. Tech: 4 years (100 Credits)
- For every other entrant, the duration of the PhD fellowship is 5 years. The PhD curriculum has been developed within this framework.

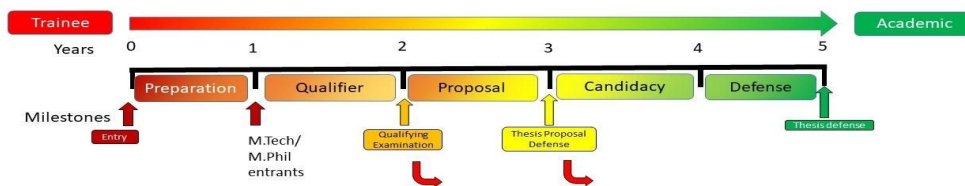

- Qualifying exam at the end of year 2
- Thesis proposal defense and advancing to candidacy year 3
- Thesis defense at the end of year 5
- If student/trainee is unable to clear the qualifying exam or the thesis proposal they will be asked to leave.

Elaborating the milestones briefly:

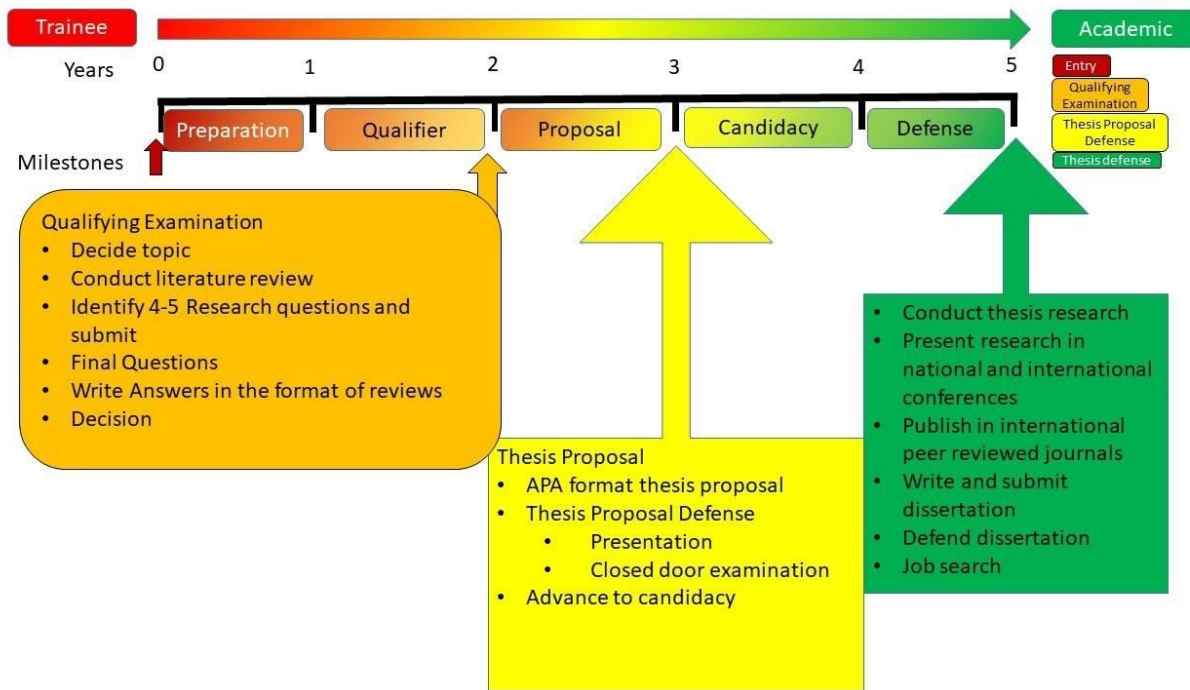

Tentative guidelines are provided below for structuring each year of the PhD Program

Between selection and enrollment

- After the students have been selected for admission, they will actively correspond with the potential thesis advisors and finalize this by a process of mutual agreement. This should be completed as soon as possible but no later than July 1, 20xx for a September 20xx admission.
- Familiarize yourself with the proposed project(s) you will be working on for the first two years of your PhD. One of these could potentially become your dissertation project.
- Using the time between selection and enrollment, the prospective student is encouraged to think and formulate a plan for their tenure at Ashoka University. Sample but not exhaustive pointers to think about could be
 - What are your strengths? (academically, and non-academically) How will these strengths become complementary to your advisor’s expertise for the project(s) discussed? How well do you fit in to the research group?
 - What are your weaknesses? (academically and non-academically). How can you improve yourself in these areas using the resources and the PhD experience at Ashoka University?
 - How well do you understand ethical issues for responsible conduct of research and academic integrity? If there are gaps, which areas do you need to address first?
 - What are your short term and long-term goals? How can the PhD Program at Ashoka University help you attain those?
 - What parallel skills can the program give you in addition to theoretical and technical expertise directly related to your PhD program?

All these will be essential in writing your Individual Development Plan (IDP) at the very beginning of year 1 and every subsequent years. This is a program requirement and cannot be waived for any student.

Year 1 (25 credits)

1. Deadline to declare primary advisor (s): **September 15**
2. **Monsoon Semester:**
 - a. One Core Course (4 Credits), One elective course (4 credits) or 2 Core Courses (4+4=8 credits) or 2 electives (4+4=8 credits) (Make SRM1 mandatory?)
 - b. Psychology Journal Club= 1 Credit
 - c. Graduate Research Seminar = 1 Credit
 - d. Research activities- 2 or 3 Credits

Spring Semester:

- a. Graduate research methods (4 Credits), One course (4 credits) (Make SRM2 mandatory?)
- b. Psychology Journal Club= 1 Credit
- c. Graduate Research Seminar = 1 Credit
- d. Research activities- 2 or 3 Credits

Mandatory workshop:

Science Communication ((Good presentation skills, effective ways to deliver concepts, speaking to a lay audience versus an expert audience)

Based on the student's background, the advisor and the student will determine a set of courses (core or elective) the student needs to take during years 1 and 2, and possibly additional courses in latter years if these courses are relevant. The availability of courses, the nature of the proposed PhD project, and the prior training of the student will all decide the exact nature of the courses the student will pursue.

3. Student training will involve statistical training, data analysis, research design, scientific writing, citations, presentation, management and dissemination of data (including issues concerning data privacy, data protection, data ownership, and intellectual property rights), and programming. These are mandatory.
4. *For SRM-1 and SRM-2 PhD students will take the lectures and the examinations with the undergraduate students but they will not be part of undergraduate group projects. That part of their course grade will be dedicated to their advisors, who would be expected to write assignments for their PhD students, grade the work and provide the course professors of SRM-1/2 with their assessments for the allocation of grades.*
5. All students will take coursework on ethical practices in social science and behavioral research. Unless a centralized ethics course is created, thesis advisor will take this responsibility to train students on matters of ethics in year 1. This is in addition to what will be taught at the end of year 2 in the workshops.
6. Through years 1 and 2 students will also gather preliminary data in order to write their thesis proposal documents.
7. Students will submit an individualized development plan (IDP) by **October 1 to the advisor and the PhD Coordinator**. At the annual review, the IDP will be followed up on. For details on how to write an IDP students will receive guidance once admitted
8. Annual review will be conducted with collaboration with the mentor and submitted to the graduate coordinator no later than **May 28**.

Year 2- The Qualifying Year (25 Credits)

9. **Monsoon Semester:**
 - a. One Course (4 Credits) (recommended: otherwise add to research/teaching credit)
 - b. Psychology Journal Club= 1 Credit
 - c. Teaching practicum- 1 credit

CONFIDENTIAL

- d. Mandatory workshops (0.5 credit)
Reading for your literature review: Primary Literature searching using databases, collating search, creating a bibliography and maintaining, updating citations

Spring Semester:

- e. One Course (4 Credits) (recommended, otherwise add to research/teaching credit)
- f. Psychology Journal Club= 1 Credit
- g. Teaching practicum- 1 Credit
- h. Mandatory Workshops (0.5 Credit) : Scientific Writing (Writing a research literature review)

By the end of the spring semester in year 2, you should complete the minimum requirement of 24 coursework credits

10. Over the year credits devoted to research: 4 Credits

11. **The Psychology PhD qualifying exam (6 credits):**

The purpose of the qualifying exam is to judge whether the student has enough theoretical knowledge and grasp of primary literature in his/her field of research, and is adequately poised to launch a dissertation project. This examination will be in a descriptive format and will be spread over both semesters of the second year. The monsoon semester will be devoted primarily to reading and understanding the literature and identifying pertinent research questions and the spring to articulately summarizing current research and writing them in the form of a series of mini reviews.

- a. **By September 30th** of academic year 2, PhD students will identify a three to five member committee consisting of both internal and external faculty members. (Advisor is a part of the thesis committee) along with their IDP. The names and details of the committee members should be forwarded to the PhD coordinator via email, using the prescribed format.
 - i. **For 2020, in light of the pandemic, this deadline is extended to November 15th**
- b. At the beginning of the monsoon semester, the student will choose a topic of interest allied to the intended dissertation project. Submission deadline for chosen topic to the : **October 15th**
 - i. **For 2020, in light of the pandemic, this deadline is extended to November 20th**
- c. Each student will conduct a comprehensive literature review on the selected topic and create a bibliography of not less than 100 references. Generally, all students are recommended to create a bibliography of 120-150 references minimum. Not more than 5-6 of these should be review articles. Also, not more than 5-6 of the bibliography should be papers published ten years before the current year. Rest should be primary literature. Based on the readings, the student will identify 4-5 existing research gaps in the literature, and write 4-5 questions.
- d. A final list of 4-5 questions should be submitted to the committee members by December 1, with the entire bibliography via email
- e. The committee can keep the questions submitted intact, modify them, add their own or completely change the questions.
- f. By **December 15** students will receive the final version of the questions back from the committee. By the same date they should also submit an annotated bibliography.
 - i. For 2020, this deadline is extended to January 30th.
- g. The students will write the answers to the questions that the committee returned back to them. Each answer should be formatted like a minireview and organized in to subheaders, with a reference section of its own. The submission deadline is **March 31** (Spring semester, academic year 2).
 - i. An extension is possible for AY2020-21. This will be decided around March 1.
- h. The committee members will review the answers and return an answer via email through the student's advisor whether the student has passed the qualifying exam, will be graded a pass contingent on major or minor edits or has failed the qualifying exam.

CONFIDENTIAL

- i. Any student who has been graded a fail, or has been suggested edits, has till **May 15** to rewrite the answers.
12. If the student's progress is unsatisfactory by the end of their second year, or the student is unable to pass the qualifying examination, they will be asked to leave the programme. In exceptional cases (e.g., pregnancy), they may be granted an extended probation period of not more than 12 more months. Annual review must be submitted in the prescribed format to the PhD coordinator by **May 28**.
13. **Further guidelines on the qualifying examination**
 - a. **Goals of this assignment:** This assignment is intended to a) Expose second year graduate students to a wide range of research literature in their selected sub-area of research. This imparts a broad-based knowledge necessary to ground them in research in their chosen field. b) To prepare the literature review which will be submitted as part of their thesis proposal for advancing to candidacy.
 - b. **How to frame questions:** Identify research gaps in the literature. Try to envision, very loosely, what the literature review would look like for your thesis proposal document. What critical questions have to be addressed to frame the best possible research question and hypothesis? What is the overarching area of interest and why is that a significant research problem? Situate the importance of your work and use this assignment as an opportunity to familiarize yourself with the literature in your field.
 - c. **Once you have your final questions and bibliography:** Format each answer as an independent, APA style review. Each answer should have its own reference section. Briefly, each answer should begin with an introduction, followed by a body, organized into distinct subheadings, followed by a discussion, which will discuss the gaps in the reviewed literature, with possible research that can address this, and have a definitive concluding paragraph.
 - d. **Two workshops will aid you through this assignment:** One workshop in Monsoon, November, will address, critical reading, referencing, and building an annotated bibliography. A second workshop either during the winter break or in the beginning of the spring semester, will aid you to write the reviews.

Summer Semester (Preparation of year 3) :

Mandatory workshops: (0.5X4=2 credits)

- i. Animal Research and laboratory safety, Occupational health and safety/Human Research/ Field research ethics
- ii. Academic Integrity
- iii. Writing a thesis proposal and Dissemination of data (How to make up composite figures for presentation and publication, how to create quality posters for research conferences)
- iv. Pedagogy (Elements of course design, modes of student learning, Writing Assignments, Grading Student work, Writing a good syllabus)

Year 3: The Proposal Year (25 credits)

14. Monsoon Semester:

- a. Psychology Journal Club= 1 Credit
- b. Graduate Research Seminar = 1 Credit
- c. Teaching assistantship- 2 credit

Spring Semester:

- i. Psychology Journal Club= 1 Credit
- j. Graduate Research Seminar = 1 Credit
- k. Teaching assistantship- 2 Credit

15. Submit an IDP by October 1.

16. **Research activities for this year will be worth 7 credits** total disbursed by the agreement of the student and the advisor through the semesters.

Psychology Thesis proposal exam (8 credits) :

17. **By November 15th** of their third academic year, students will submit the first draft of their thesis proposal document, styled as an APA project proposal to their thesis committee. The students will be encouraged to turn this proposal to a funding application from external sources.
18. By the end of the semester students will present their thesis proposal defense followed by a closed examination with the thesis committee. On passing the proposal defense, students will advance to PhD candidacy and be registered for a PhD. Following the thesis proposal, student should schedule biannual committee meetings with the thesis committee to track progress until the defense of the thesis.
19. Depending on the opportunity and funding, students may apply to be a visiting scholar at another university for a limited period of time. The learning outcomes of such visiting positions must be discussed with their advisor(s).

Summer workshops (Preparing for year 4):

Mandatory workshops (0.5X2= 4 credits)

- i. Applied statistical/programming training (*research specific- student and advisor will decide*)
- ii. Specialized methods training (*research specific- student and advisor will decide*)
(*If such training is not needed, please talk with your advisor about adjusting these credits with your research or teaching assistantships*)
- iii. Pedagogy-I (Elements of course design, modes of student learning, elements of course design)
- iv. Pedagogy-II (Writing Assignments, Grading Student work, Writing a good syllabus)

Year 4: Candidacy Year (25 credits)

20. Monsoon Semester:

- a. Psychology Journal Club= 1 Credit
- b. Graduate Research Seminar = 1 Credit
- c. Teaching assistantship- 2 credit
- d. Research- 8 credits

Spring Semester:

- l. Psychology Journal Club= 1 Credit
- m. Graduate Research Seminar = 1 Credit
- n. Teaching assistantship- 2 Credit
- o. Research- 8 credits

Summer Semester (Preparation for year 5)

Workshops (0.5X2= 1 credit)

- p. Effective conference strategies
- q. Thesis writing I
- r. Alternative careers for PhDs (no credits)

21. IDPs are due by October 1
22. Bi-annual SRC meetings are required, with reports submitted to the coordinator at the ends of monsoon and spring semester
23. Annual review submitted by May 28.

Year 5: The defense year (25 credits)

24. Monsoon Semester:

- a. Psychology Journal Club= 1 Credit
- b. Graduate Research Seminar = 1 Credit
- c. Teaching assistantship- 2 credit

CONFIDENTIAL

d. Research- 8 credits

Spring Semester:

- s. Psychology Journal Club= 1 Credit
- t. Graduate Research Seminar = 1 Credit
- u. Teaching assistantship- 2 Credit
- v. Research- 8 credits

Summer Semester (Preparation for year 5)

Workshops (0.5X2= 1 credit) (Might have to be administered in the winter break)

- i. Effective academic job search strategies, Writing research and teaching philosophy statements
 - ii. Writing good grants, turning a thesis to a paper
25. IDPs are due by October 1
 26. Bi-annual SRC meetings are required, with reports submitted to the coordinator at the ends of monsoon semester and spring semester.
 27. Through years 4 and 5. The students will be expected to present their research in reputable national and international conferences, symposia and meetings in the field, contingent to applying and obtaining funding support from appropriate bodies. Students are highly encouraged at this stage to seek extramural travel funding from conference organizers.
 28. Ashoka University has a fund of 2 Lakh rupees available for PhD students for a one time international travel to a major conference.
 29. The following is excerpted from the official PhD guidelines of the University.
 - a. "Once admitted to candidacy, the student must:
 1. write up his/her research in the form of one or more research or working paper(s) and present them at peer-reviewed research conferences/workshops of international repute, submit them for publishing in peer-reviewed journals of international repute, or write up his/her research as a compilation of essays to be published as a book (note, subject to approval by Dean of Research), individual departments will develop acceptable norms for the manner (viz. form and forum) in which research should be placed for public access, review and study)
 2. document the outcome of his/her research in the form of a draft PhD dissertation
 3. subject the draft dissertation for possible plagiarism using a standard software
 4. present his/her work in the form of an open seminar in Ashoka University before an audience that includes members of his/her SRC, and
 5. submit the draft dissertation to his/her SRC for its (internal) assessment.
 30. Pursuant to clause 23(1), the Department of Psychology further notes that, students are expected to publish their research in peer reviewed journals that are internationally reputable. Bear in mind that non-internationally reputable outlets will not be considered, and might even work against you in your career. **At least one article accepted, in press, or published is highly recommended before a thesis defense is scheduled.** Students should note that publications in other forms (e.g., book chapters, encyclopedia chapters, policy papers, user manuals) may not be well-regarded, except when the (expected) impact of their work in such outlets is recognized (e.g., a chapter in *Handbook of Social Psychology*).

Post Defense evaluation of thesis (University guidelines)

31. Post a positive assessment by SRC, the PhD dissertation is sent to at least two external researchers, and to supervisor(s) for their formal assessment and recommendation.
32. A panel of six external examiners is identified by the supervisor(s) and vetted by the Programme Coordinator. The Dean (Research) will select the first two examiners from the panel and seek their agreement to examine the dissertation. In case an examiner is unavailable, the Dean will go down the list

CONFIDENTIAL

and explore other names in the order in which the names are listed. While going down the ordered list of potential examiners, the Dean may skip an examiner, but do so only after consulting the concerned Programme Coordinator and putting his/her reason(s) for doing so in writing.

33. Each external researcher recommended by the Programme Coordinator should be currently active in the research area as *evidenced* by his/her recent research publications.
34. Each external examiner as also each supervisor and co-supervisor will independently recommend either of:
 - i. “the dissertation is accepted without any revision”,
 - ii. “the dissertation is accepted subject to suggested changes/clarifications are incorporated in the dissertation and presented at time of viva-voce”
 - iii. “the dissertation is revised and submitted for re-examination”,
 - iv. or “the dissertation is rejected outright”.
35. Once, the “dissertation is accepted without any revision” or “the dissertation is accepted subject to suggested changes/clarifications are incorporated in the dissertation and presented at time of viva-voce” unanimously by the external and internal examiners, the SRC will formally conduct a viva-voce examination in the presence of at least one, but preferably both, external examiners.
36. The examination will be open to all faculty members and students from Ashoka University.
37. Post viva-voce, a copy of the dissertation is deposited with the INFLIBNET, and with Ashoka University Library.
38. Before they graduate, students should aim to have some international reputation, through their published work, conference presentations, and involvement as reviewers of reputable journals.
39. All students and candidates will abide by policies and standards laid out by the committees of the University with respect to ethics, academic honesty and integrity, professional conduct, disciplinary infractions, and sexual harassment at all times. If there is a conflict between University policy and Departmental policy, university policy will take precedence.

Funding

A limited number of Ph.D. fellowships will be offered by Ashoka University to support Ph.D. students (as per the rules and regulations of the University). The junior research fellowship includes a monthly stipend of INR 35,000 per month, a contingency grant of INR 20,000, and offers extensive teaching opportunities. There is no additional stipend for teaching. Once the student advances to candidacy, the fellowship increases to INR 40,000 per month. The compensation structure is subjected to periodic review by the university.

The monthly stipend and annual contingency grant given to Ph.D. students who receive other scholarships (from UGC, CSIR or a partner organization) will be decided based on terms covering the scholarship itself and as per the regulations of the University. Students will also be offered housing on campus, subject to availability). In case on-campus housing is not available, Rs. 7000 per month rent allowance will be paid towards off-campus housing.

Faculty handbook

Undergraduate Education

Framework

In terms of content, we follow the American Psychology Association’s *APA Guidelines for the Undergraduate Psychology Major*. In particular, the Guidelines have five goals:

Goal 1: Knowledge Base in Psychology

CONFIDENTIAL

- Goal 2: Scientific Inquiry and Critical Thinking
- Goal 3: Ethical and Social Responsibility in a Diverse World
- Goal 4: Communication
- Goal 5: Professional Development

Philosophy

The department's core education philosophy is, "Teaching has not occurred if learning hasn't." At Ashoka, teaching is not a top-down exercise where the Instructor exerts authority on content and didactics, and sees teaching as a one-way transmission of knowledge.

Suppose you have three students: the competent, the average, and the academically poor student. Instructors must think of one fundamental question: at what level should the Instructor teach?

Curriculum Structure

Twelve courses (48 credits) are required for a major in Psychology, and a further four courses (16 credits) are needed for an advanced major during the ASP year. The UG curriculum broadly follows a "tree structure" (see Appendix F), with the basic courses in Gateway/Thinking like a psychologist, two SRMs, and five course domains. The rest of the courses are electives. The structure of the psychology curriculum resembles a pyramid, with Fundamentals (Gateway, Statistics and Research Methodology) at the top-tier, Core Domains (Biological, Cognitive, Developmental, Clinical, and Social Psychology) in the middle-tier, and Electives at the lower-tier. Students are encouraged to complete their Fundamentals and Core Domains as early as possible, because many of these are prerequisites for upper-level electives. For more information, please click [here](#).

All electives are expected to have an interdisciplinary focus across a few core domains, even though for representational purposes, the electives are housed under a particular core domain. The intention of this structure makes it clear to students at each level where their intellectual bases are being built. For example, second-year students should know that in order to be eligible for electives, they need to clear their core domains as early as they can.

Course Syllabus

The course syllabus is like a contract with students detailing course goals, expected learning outcomes, content to be covered over each class of the semester, reference material, grading and assessment criteria, assignments, deadlines, class policies, etc. Once presented to students, instructors should not wilfully change the details in the Course Syllabus, unless there are good reasons to do so (e.g., disruption of classes). Before the start of each semester, the course syllabus must be archived for future reference. At present, the University does not require new courses to be approved by any authority. However, it would be prudent for faculty wishing to launch new courses to seek feedback from colleagues, both within and outside Ashoka.

Assessment

Assessment should follow from learning goals (objectives) as set out in each Course Syllabus.

Level 100 – Gateway: The instructor has to balance class size with grading time. Hence multiple-choice and short-answer questions are OK at this level (but are not ideal at upper levels).

Level 100 – SRM I and II: Only scenario-and/or reasoning-based questions (i.e., application type) are allowed. In some cases, instructors may want to test discussion-type reasoning (e.g., "Why should Bonferroni corrections be applied instead of Tukey's posthoc tests?").

CONFIDENTIAL

Level 200 courses and beyond: At a university level, students should have moved beyond description and explanations. Therefore assessment should follow Anderson and Krathworl's taxonomy for learning in higher education where the emphasis is on creating, evaluating, and analyzing theories learnt in class. Where final examinations and term essays are involved, only discussion-type questions are allowed and students can generally expect 3 essay questions to be answered within 2 hours.

The exam questions themselves should be big questions in the field, not small questions about particular papers or any one theory, much like what a typical *Current Directions* article or *Psychological Science* commentary is like. In addition, because psychology is heavily based on empiricism, instructors must ensure that students give examples of empirical work in their answers. Instructors must set the right directions for students' growth such that they will be able to answer these sorts of questions. It makes students learn the content deeply if students know from the start of their course that their exams would be testing their ability to integrate and evaluate knowledge.

Readings

Level 200 – Readings must be appropriate to students' stage of development, and must align with the course's objectives, as well as the general curriculum's objectives. Core courses should have minimal integrative review papers. However, students must be exposed to empirical readings. Readings must be carefully chosen, especially where statistics and methodology are concerned. Instructors should not assign readings that they themselves are fascinated by; instead, they need to think from a pedagogical perspective what the reading should accomplish. *Psychological Science* articles are generally suitable for Core Courses because they are short, top-class, and heavily copy-edited to make them accessible to non-expert readers. Students can be slowly introduced to theoretical review papers and more technical empirical readings after their Core Courses.

Student workload

Workload should not exceed 10 hours per week per course. All courses should go by these indicators:

- (A) Classroom contact hours
- (B) Revision of classroom content
- (C) Preparatory time for classes

For example, a typical Ashoka curriculum involves 3 hr of classroom contact time, and students may require 3 hours of revision, and another 3 hours of reading as class preparation. Hence the A-B-C division could be 3-3-3.

Final grade calculation

At present, the psychology department does not adhere to any particular formula for converting numeric grade to letter grades. Absolute measures (i.e., predetermined cutoffs) and relative measures (e.g., letter grades based on curving the distributions) are both acceptable. If absolute measures are used, it is wise to formalize it in writing in the Course Syllabus.

Attendance policy

At present, faculty have the freedom to set their own attendance policy. Attendance policy of individual classes must respect general guidelines given by the Office of Academic Affairs. For example, more flexible attendance policies may be implemented when:

- (1) Students are representing the University in events, or representing their state or country;
- (2) Students have a letter of excuse from the Office of Academic Affairs;
- (3) Under extenuating circumstances (e.g., death of a family member).

Punctuality policy

Even with the attendance policy in place, students can still appear at the last minute and count their appearance as 'attendance'. There is no standard punctuality policy, but some faculty award 0.5 marks for non-punctual attendance.

Plagiarism policy

We will adopt the plagiarism policies set by the Office of Academic Affairs. However, it is wise to reinforce it in our Course Syllabus, especially in first- and second-year courses where many students are not familiar with the seriousness of plagiarism.

Graduate Education

The PhD programme trains the next generation of rigorous, confident, responsible, and competent scholars who will address important problems, problems where the answer matters to science in particular, or to humanity in general (Medawar, 1979, *Advice to a Young Scientist*). Our PhD programme began in Monsoon 2019. At present, we are not restricting entry into the programme based on the candidate's undergraduate major, as long as they can demonstrate how their major can help them in their PhD degree. For more information, see Appendix G, which is the recruitment advertisement for the 2019 call for applications.

Best Practices in Teaching

Faculty must engage in pedagogy literature. Ken Bain's *What the best college teachers do* is a good start. Faculty can benefit by pairing up with each other and visiting each other's classes and providing feedback. This should be done on a voluntary basis. Consider asking someone to pair up with you and exchange one or more visits. This is an excellent way to get new ideas for teaching, and to become more self-reflective about your teaching. Be supportive colleagues; help one another to succeed.

Techniques to Engage Students in Large Lecture Courses

- Walking around the room, making eye contact.
- Asking for a show of hands about who thinks X, who thinks Not-X, and then calling on someone from each group to explain.
- Asking students to spend two minutes talking to their neighbor on a thought question, and then calling on students to report back.
- Personalizing the content with case studies and interesting biographical information about key theorists and researchers.
- Speculating about potential practical applications of newly emerging theories and findings, making sure that the students know that you are speculating
- Doing demonstrations in class for phenomena where this can work (detection/RT, various kinds of social judgments, etc.).
- Using animations for explanations of processes.
- Asking students to analyze the design of a study (e.g., between, within, experimental, correlational), and asking them to justify the design needed in order to answer specific questions.
- Asking students whether they are convinced by a particular interpretation of a finding and following up with why/why not.

Techniques to Engage Students in Small Lecture Courses

- Assigning students to groups at the beginning of the semester. Periodically ask them to spend time discussing a question as a group, then appointing a spokesperson to report back.

CONFIDENTIAL

- Assigning formal debates.
- Breaking into smaller groups for presentations of additional reading (This is a nice way to incorporate primary articles—each individual student is only responsible for 1-2 through the semester, over and above the assigned reading, but gets to hear about many. The instructor can circulate among the groups and grade the hand-out created by each student.)

Teaching guidelines for hallmark courses for the department

Gateway to psychology

Instructors should use demonstrations to introduce psychological principles as far as possible. Experiential learning has been proven to be effective in scientific education (Kolb, 1984). There are many tried-and-tested demonstrations as reference, e.g., *Handbook of Teaching Activities and Demonstrations in Psychology*, *Teaching of Psychology*, etc. Experiential learning can be supplemented with critical thinking, although because many students would be taking a Critical Thinking Seminar in psychology, the role of critical thinking in Gateway would be less important.

From Spring 2018, we have introduced a Research Participant (RP) component (see section on “Policies”). Gateway instructors should spend time the first or second class explaining the RP component to students, talking about how research participation can help students in their learning process. Doing so may increase motivation to participate.

Thinking like a psychologist

Students in the 2016 and 2017 batch who had been granted a Gateway waiver (because they had taken high school psychology courses) were ill-prepared for the requirements of Core Domains. However, these students are likely to find a traditional Gateway course unchallenging because the content taught in Gateway mirrors their high school psychology curriculum.

As such, we devised *Thinking like a psychologist*, to be offered only to students who have student psychology at a pre-college level. The focus of the course is not on understanding introductory psychological concepts – that is reserved for Gateway – but on building the skills to think like a psychologist.

Statistics and Research Methodology (SRM)

SRMs I and II must be taught as an integrated two-semester course because statistics and methodology are deeply intertwined. In cases where different instructors are teaching SRM I and II, the knowledge gaps in SRM I must be communicated such that SRM II makes up for any gaps. In addition, SRM-like content should be integrated into Core Domain courses, wherever appropriate.

Instructors should not rely solely on ‘standard’ statistics textbook. The mathematical core of statistics have been constant for decades but the practice of statistics has shifted dramatically since 2011. As the development unfolds, the practice of statistics must be continuously updated with the standards of the field.

SRM instructors should not be overly ambitious at covering advanced topics such as ANCOVA, MANOVA, mediation analyses (bootstrap; Sobel, Baron & Kenny), structural equation modeling, multilevel modeling, network analyses, meta-analysis, dyadic analyses, principle components analyses, Python programming, etc. These cannot be accommodated within a standard 13-week course. If need be, these can be taught in advanced statistics/methodology classes, or as part of a student’s research project with his/her supervisor.

CONFIDENTIAL

Students must also be familiar with syntax, whether in R or SPSS. In addition, students must master how to report results in a clear, complete, and unambiguous manner.

SRM I

SRM I will be more statistics and less methodology. These are the topics that must be taught:

- The scientific method
- Measurement
- Describing data: Visualization
- Describing data: Central tendency and dispersion
- Covariance and correlation
- Sampling distributions
- Introduction to hypothesis testing
- T-tests
- Chi-square
- ANOVAs
- Regression
- Inference using estimation and confidence intervals
- Statistical power

In addition, students must analyze a large dataset from archival data (e.g., World Values Survey, General Social Survey). Many of these dataset are publicly available from government agencies and NGOs (World Bank, UN, etc.). The idea is to familiarize student with formulating hypotheses and testing them empirically. The instructor should not overly focus on the soundness of the theoretical formulation. Leave that for their theoretical courses.

SRM II

SRM II will have a stronger focus on methodology and less on statistics. Students must have sufficient sessions to read full-length simple empirical papers and critique the statistics/methodology.

In addition, students must do an empirical project, preferably a factorial experiment. Again, the instructor should not overly focus on the soundness of the theoretical formulation. These topics must be taught:

- Psychometrics: Reliability & validity
- Introduction to experimental research
- Control problems in research
- Single-factor designs
- Factorial design: Fully independent, fully dependent, & mixed designs, including all post hoc analyses using /EMMEANS syntax (in SPSS). If an instructor is using R, afex is a good package to analyze factorial designs and its post hoc analyses.
- Correlational, observational and survey research methods
- Quasi-experimental designs
- Small N designs
- Ethics

Independent Study Module (PSY 3099: ISM)

ISMs provide opportunities for students to obtain a personalized specialization on a specific topic. They should never be an easy way out of a standard class, neither in terms of workload, hours spent, or rigor. Instructors can consider having a unique set of ISM requirements tailored to particular students' (or group

CONFIDENTIAL

of students') stage of learning. For example, a second year student who has not taken SRM II may be assigned research assistance as part of learning (20%), and be assessed on his or her reflections of the experiences (40%) and theoretical understanding of the project he or she is running (40%). For more advanced students, they may want to do a full-fledged project, and the grading components can be based on different components of the project.

The Instructor has the autonomy to decide whether to take on a student or not. At present, taking on ISM students does not count towards an instructor's teaching load, although Instructors may find that having ISM students may benefit their research agenda.

Internship to Psychology Instruction (PSY 4070)

Across disciplines, teaching assistants (TAs) provide crucial support in the classrooms. Ashoka's Psychology Department offers a 4-credit *Internship in Psychology Instruction* (PSY 4070) for senior students. Besides providing alleviating faculty workload, undergraduate teaching assistants (UGTAs) have also been shown to make the classroom environment more learner-centric (Gordon et al., 2013). In the process, UGTAs also learn public speaking and communication skills, strengthen their understanding of psychology, develop an appreciation of pedagogical and higher education issues, and gain teaching experience on their CV for graduate school (possibly increasing scholarship chances), and in general enhance their personal growth (see Weidert et al., 2012; Filz & Gurung, 2013, for reviews). Students in a course with UGTAs also benefit from the additional help UGTAs provide (Fernald et al., 1975; McKeegan, 1998).

In short, UGTAs have been shown to provide benefits to faculty, students, and interns themselves. These benefits can only be achieved if interns are well-trained and well-supervised throughout their internship. The training is detailed in the Course Syllabus for PSY 4070.

Requirements for Instructors

When a UGTA is assigned to a course, the faculty member in charge of that course is expected to provide UGTA training and supervision. At the beginning of the quarter, the faculty member should meet with the UGTA to explain his/her duties and responsibilities. After the initial meeting, regular weekly meetings with the UGTA are recommended. Instructors who want UGTAs must fulfil the following criteria:

1. Consider the UGTA experience as a way to enhance the intern's professional development;
2. Be willing to help interns learn about education and pedagogy rather than merely treating interns as additional manpower;
3. Complete reading Ken Bain's (2004, 2012) "*What the best college teachers do*" and "*What the best college students do*", and/or other substantive literature on the scholarship of teaching;
4. Take full responsibility for course grades and learning outcomes of the class.

In addition, Instructors should note that training a UGTA takes up the Instructor's time, and according to OAA's regulations, GAs/TAs cannot grade assignments with unstructured answers. As such, Instructors who do not feel that it is worth their time and effort to train UGTAs should not take up a UGTA.

Requirements for prospective interns

Undergraduate students have the opportunity to become teaching assistants (interns) of Basic and Core Domain courses if they fulfil the following criteria:

1. Are enrolled as fourth-year psychology majors;
2. Are in good GPA standing;

CONFIDENTIAL

3. Have promising teaching traits (e.g., emotional stability, motivation, positive learning attitude).¹

Course registration procedures for prospective interns

1. PSY 4070 will be published in the Course Catalogue.
2. One week before official course registration on LMS, students express interest to take PSY 4070 by submitting to the TA/TF Programme Coordinator: (i) their transcript; (ii) a letter of motivation; (iii) a rank-ordered list of courses they want to teach.
3. The TA/TF Programme Coordinator will contact the student within the week to confirm if the student is suitable to take PSY 4070.

Special considerations and safeguards

Grading

UGTAs can only grade assignments and/or exams that have structured answers, such as multiple-choice questions, and short answers. They are not allowed to grade questions that have unstructured answers such as lab reports, essays, and projects.

Limits

UGTAs are assigned to one section of a course; they are not assigned to the faculty. This means that a faculty who has a UGTA may not deploy the UGTA for another course that the UGTA did not sign up for.

Conflict of interests

UGTAs may be in situations where there may be unavoidable conflicts of interests or out-of-class relationships with their students, such as being in the same CCA group as their student. Conflicts of interests, whenever they are detected, must be reported to the Instructor, and risk management strategies must be worked out.

Interns cannot initiate sexual and/or romantic relationships with any student in their class at any point during the semester. If a UGTA was already in such a relationship with the student before semester started, then he/she should not be a TA for that particular course, but should instead choose other courses to be a UGTA. The UGTA will cease becoming a UGTA for that course in the event of a sexual/romantic contact. This may mean that the UGTA will fail the course, if such conduct happens early in the semester. The UGTA may still be able to pass the course, if it happens late in the semester (especially after the practicum lecture is given).

Teaching assistantships

From AY2018/2019, there are several systems of teaching assistantships (TA) and teaching fellowships (TF). If a course has TAs/TFs, the responsibility of the course still falls entirely on the Instructor. It is the responsibility of the Instructor to plan learning goals for the TA/TF, and the Instructor must play a mentoring role to groom the TA/TF. TAs/TFs will not be seen merely as 'workers' for teaching support, but as active shapers in the course. For example, TAs/TFs should be encouraged give feedback to the Instructor on his/her teaching style, give feedback on the curriculum, express the concerns of students, etc.

¹ See Filz and Gurung (2013) for a list of traits possessed by an ideal UGTA.

CONFIDENTIAL

Under ordinary circumstances, SRM I and SRM II have priority over all other courses for TA/TF support because the nature of these two courses requires more academic support. For example, many students have statistics anxiety and because of the nature of data analyses that is integral in both courses, students will require more intensive guidance.

Teaching Fellows (TFs)

TFs are full-time paid positions. The Office of Academic Affairs has stipulated that courses with class sizes above 45 are eligible to apply for a TF. There must be enough work to justify a full-time position.

Traditionally TFs have a master's degree but from AY2018/2019, candidates with a bachelors' degree from Ashoka may be considered. TFs may teach any courses, and are allowed to participate in grading.

MLS Teaching Assistants (MLS TA aka Graduate Assistantship or GA)

MLS students have to fulfil a 2-credit TAship (unpaid) per semester as part of their contract. It is possible to do twice the teaching load in one semester (i.e., $2 \times 2\text{-credits} = 4\text{ credits}$), thus freeing up the other semester entirely. This can sometimes be more productive for the MLS student especially if the two courses are of the same kind but in different sections.

MLS TAs may teach any course, as long as they are not students of that course. They do not have a choice of which courses they will TA for, although they may be consulted on their preferences. MLS TAs may be allowed to grade, but this strongly depends on their competence.

Undergraduate Teaching Assistants (UGTA; ref. PSY 4070)

The Department offers a course titled PSY 4070 Internship for Psychological Instruction to Year 4 students. This TAship is credited and unpaid. UGTAs are encouraged to only be TAs for Level-100 and -200 courses, and only for 300 level courses they have taken. See [policy on PSY 4070](#) for more details. Under ordinary circumstances, TAs are not allowed to grade papers where the answers are not fixed. TAs can frame multiple choice questions and grade short answers, provided an answer key is worked out beforehand between the Instructor and the TA.

Peer tutors

UG3 and UG4 students who are particularly strong in certain aspects (e.g., data analysis, experimental design, academic writing, presentation skills, slide design, etc.) may be recruited as peer tutors to help academically weaker students. This is a purely teaching role; no administrative work (e.g., grading, syllabus planning, setting exam questions, invigilation, etc.) or class attendance are expected. Essentially this is akin to a "helpdesk" (like those in the Math Dept, or CWC). The remuneration is Rs 250 an hour, capped at 5 hours per week; these conditions of employment are subject to the University's guidelines for student employees. Faculty who wish to recruit peer tutors must gain permission to appoint the person from the Dean of Academic Affairs, the HOD, and have the contracts prepared by HR.

Volunteer Teaching Assistants (VTA)

VTAs are not paid from the university's or the department's budget. Anyone (e.g., ex-UGTA) can volunteer to be a teaching assistant, as long as the particular instructor agrees. The Programme Coordinator must be informed.

Summary

The table below summarizes the various schemes:

	TFs	MLS TA	UGTA	Peer tutors	VTA
Person-in-charge	HOD/HR	HOD	Instr	Instr/DAA/HR	Instr

CONFIDENTIAL

Contract	Full-time	2 credits	4 credits	Per hour	Depends
Max. working hours per week	40	5	10	5	Depends
Allowed to grade unstructured answers?	Y	Depends	N	N	Depends
Allowed to grade structured answers?	Y	Y	Y	N	Depends
Courses allowed to assist	Any	Any	Lvl-100/-200	Lvl-100/-200	Depends
Administrative load within course	Full	Full	Some	None	Depends
Class size restriction	> 45	None	None	None	None

Administration

Administrative assistance

From Aug 2018, the Department will have a full-time assistant/deputy administrative manager. The job scope of the administrative manager are (but is not limited to):

- Coordinate itinerary external visitors
- Coordinate and organize departmental-level activities (e.g., colloquium)
- Compile departmental level statistics (e.g., pass rates, attendance)
- Scheduling thesis colloquium (monsoon), thesis defense (spring), etc.
- Disseminate information to psychology undergraduates (but not any course in particular)
- Invigilate exams *together with* the chief invigilator, especially for large classes
- Serve as undergraduate research coordinators for thesis (scheduling proposal defense, thesis defense; collecting research participation forms for Gateway students)
- Lab manager (scheduling, keys, maintenance, procurement)
- Ensure that remunerations to third-parties have been processed
- Maintaining department website

The reporting manager of the assistant/deputy manager is Anirban Chakraborty, the Dean of Faculty and Research office.

Annual Administrative Workplan

Monsoon semester

Period	Task	Person	Remarks
--------	------	--------	---------

CONFIDENTIAL

Pre-Monsoon semester	Finalize teaching timetable	HOD, faculty, OAA	Order of priority: fly-in faculty, mothers with young children, faculty who live in Delhi, faculty who live on or near campus
Pre-Monsoon semester	Confirm teaching assignments of MLS TA, UGTA	HOD	
Pre-Monsoon semester	Orientation of new faculty	HOD	Ensure they understand the guidelines (workload, grading, TAs); advise them on their course syllabus
Monsoon course registration	Answer queries about courses	Any	
Orientation week, usually on Mon or Tue	Orientation: Department representative gives an introduction over a few sessions to UG1s	Any	Showcase the diverse spectrum of psychology; introduce some colleagues' work
Start of Week 1	Upload syllabus to Google shared folder	All	Everyone must upload; this is important for audit purposes and for us to keep abreast of what other colleagues are teaching, what materials they are using, etc.
Start of Week 1	Welcome MLS students	HOD; Dept MLS coordinator	Ensure that MLS students know the requirements for the MLS diploma; dispense general advice
Sep	Department meeting	All; colloquium coordinator; Secretary	Plan for colloquium
End of Week 2	Compile mailing list across all PSY courses; share this with all colleagues and AAB rep	Secretary	
End of Week 3	Bulk purchase of library books	HOD	
Week 3	Plan for faculty recruitment	HOD; DFR; Tanita	
End of Week 4	Graduate school townhall	Any	Be sure to emphasize both master's and PhD programmes; introduce different systems around the world: US, EU, UK, India, East Asia, Aust/NZ

CONFIDENTIAL

[Week X]	Townhall (non-graduate school topics)	HOD, AAB rep	Seek advice from AAB rep and address any ground sentiments
Oct	Department meeting	All	
End of Week 6	Prepare to launch mid-semester feedback (Week 7), in consultation with AAB rep and Education Ministry	HOD, AAB rep	
End of Week 10 (approx.)	Finalize Spring course catalogue	OAA, HOD	For each course, these must be submitted to OAA: title, code, description, prerequisite(s), and preclusion(s). Keep course descriptions to 3 sentences, although longer course descriptions may appear in the faculty's syllabus. For the purpose of the course catalogue, it is worth noting that all course descriptions are wrong, but some are more useful than others. Hence, exclude any nondescript information.
End of Week 12	ISM presentations	Student rep	
Dec	Department meeting	All	
End of Week 14	Review faculty teaching evaluations, if needed	HOD, OAA	

Spring

Period	Task	Person	Remarks
Pre-Spring semester	Finalize teaching timetable	HOD, faculty, OAA	Order of priority: fly-in faculty, mothers with young children, faculty who live in Delhi, faculty who live on or near campus
Pre-Spring semester	Confirm teaching assignments of MLS TA, UGTA	HOD	
Spring course registration	Answer queries about courses	Any	
Week 2	Department meeting	All	

CONFIDENTIAL

End of Week 2	Compile mailing list across all PSY courses; share this with all colleagues and AAB rep	Secretary	
End of Week 3	Bulk purchase of library books	HOD	
[Week X]	Townhall (non-graduate school topics)	HOD, AAB rep	Seek advice from AAB rep and address any ground sentiments
Feb	Department meeting	All	
Mar	Department meeting	All	
End of Week 6	Prepare to launch mid-semester feedback (Week 7), in consultation with AAB rep and Education Ministry	HOD, AAB rep	
End of Week 10 (approx.)	Finalize Monsoon course catalogue	OAA, HOD	For each course, these must be submitted to OAA: title, code, description, prerequisite(s), and preclusion(s). Keep course descriptions to 3 sentences, although longer course descriptions may appear in the faculty's syllabus. For the purpose of the course catalogue, it is worth noting that all course descriptions are wrong, but some are more useful than others. Hence, exclude any nondescript information.
End of Week 12	Schedule thesis defense	Thesis coordinator; Secretary	
End of Week 12	ISM presentations	Student rep	
May	Department meeting	All	Review policies, especially PSY 489, PSY 498 and PSY 499.
End of Week 14	Review faculty teaching evaluations, if needed	HOD, OAA	
End of Week 14	Archive submitted theses in library	Secretary	

Seniors' Week	Social event for graduating batch	Cultural ministry; AAB rep; Secretary; students	
Convocation	Attend convocation	All (voluntary)	
YSP week	Represent the department for YSP, if needed	OIP	

Academic Advisory Board student representative

The AAB representative reports to the Education Minister formally; s/he does not report to the Department. In fact, the HOD has no jurisdiction over the AAB. Nevertheless the AAB representative serves as a vital conduit between faculty and students, echoing any concerns from the ground to the department faculty and/or HOD. The AAB representative is nominated by the psychology students; the department should exercise veto rights in the nominee in cases where the department feels the nominee is someone with whom the department cannot work well.

Departmental Awards

The department gives out three awards before the annual convocation.

Builder's Award

This award is conferred to student(s) who have made outstanding contributions towards building up the spirit and quality of the department. This can range from hosting invited guests, organizing workshops, colloquia, or any student-driven initiatives (e.g., ISM presentations) for the benefit of students. It is not necessarily the case that the AAB representative will be awarded the Builder's Award.

M.A. Srivatsa Award for Academic Excellence

This award is donated by Dr Rangashri Kishore, in memory of her brother, for the student who has the highest GPA. As a mark of respect, appreciation, and diplomacy, this award is given directly by Dr Kishore during the departmental convocation reception.

Outstanding Undergraduate Thesis Award

This award is given to an A-grade thesis (A- and A inclusive) based purely on the quality of the thesis, not on the advisors' assessment of the student's effort. A litmus test whether a thesis is deserving of this award is the confidence and pride that one would feel about the comments the thesis would receive from a faculty external to the university. Statistical significance of the results is not a criteria for winning this award.

Research

What should faculty do research on?

All faculty regardless of rank should consult Peter Medawar's book *Advice to a Young Scientist* and Donald Stokes's *Pasteur's Quadrant*. Donald Stokes has a sophisticated view about how to balance interesting and important research. Rarely will *all* our research be both interesting *and* important, and a

diverse portfolio should be realistic. But it is safe to say that a faculty who recognizes what are important problems to solve will likely produce interesting research.

Where should faculty publish their research?

Faculty members should aim to publish in the best outlet in their field or subfield. Appendix A contains the Thomson Reuters Journal Citation Reports from 2014. The median 5-year impact factor is 2.07. Faculty should aim to publish their papers in outlets with impact factors around 2.07, though one should always keep in mind that there are specific constraints within each subfield.

Junior research leave

The department shall follow the rules set by the Dean of Faculty and Research (DFR). However, the teaching needs of the department cannot be compromised. As such, it is the responsibility of faculty who wish to go on research leave to find their own replacements. This is practical and fair – the HOD cannot possibly have the time and energy to look for replacements every time a faculty wishes to go on their research leave. The replacement must be screened by at least one other psychology faculty member. As with any faculty hiring, only the DFR has the final authority. Faculty members wishing to go on research leave should therefore plan ahead.

Book purchases

Faculty are encouraged to recommend one copy of any book which they feel is necessary for the Ashoka library to have. There is no need to order multiple copies of books. According to present university regulations, all books more than Rs 7000 need to be approved by the Library Committee. For books less than Rs 7000, the HOD has the authority to approve.

Research participation (RP) pool

The RP pool policy contains a back-end policy meant for faculty (this section), and a front-end policy meant for students.

Student participation in research is increasingly recognized as both an educational experience for students and a useful aid for psychology faculty (Bowman & Waite, 2003). Participating in research conducted by psychology faculty helps students learn about certain research areas within psychology and orients students to some of the research conducted at their university. It also allows students to learn more about psychological research by engaging in the research as a participant. From the researcher's perspective, student participation provides valuable opportunities to collect data. Thus, creating a research requirement for students is a common tool employed by many departments of psychology (Sieber & Saks, 1989).

Faculty researchers should know that having access to a research participation pool is a privilege. The pool exists because it serves an educational purpose for the Gateway students. As such, faculty researchers and their assistants should be mindful of making the participation an educational experience for their participants. This can be achieved, for example, by providing educationally meaningful debriefs. Faculty researchers who are unwilling to make the experience educational for their participants should consider alternative sources of recruiting participants (i.e., do not use the RP pool).

At Ashoka, the research participation requirement will be introduced to students enrolled in the Gateway to Psychology course; this may, in the future, be expanded to include *Statistics and Research Methods I*, but no more than these two courses. Students will be informed about the rationale for including the research participation requirement (see the section on the

information to be included in the Gateway syllabus). In implementing this policy, the faculty will closely adhere to the APA ethics code.

While participating in experiments is encouraged, not all students will participate, for whatever reasons (Elicker, McConnell, & Hall, 2010). Their rights not to participate will be respected, and effort equity (number of hours spent) between participating and non-participating students will be balanced. Hence non-participating students will be required to summarize one research article. The number of research articles to be summarized could change from time to time to balance effort equity. This means that as more research participation is expected, more research articles to be summarized is also expected.

Number of RP pool hours. The number of RP pool hours is announced at the start of Week 1, and will not change when the semester is running. However, the number of RP pool hours is expected to change from semester to semester (up to a reasonable maximum), largely dependent on the number potential studies available during the particular semester relative to the expected number of students doing Gateway in that particular semester. Bear in mind that some studies may not work out as planned, additional studies may get added, planned studies may get dropped and so on. It is impossible to balance supply and demand. Hence it is safer to require students to complete *less* hours than the total number of hours researchers require, so that all students have a chance to complete their requirements.

Instruction for Gateway Instructors. Only absolute grading can be used for the purpose of computing final letter grades.² This is because of the ambiguity of grading the summary/review articles (for students who opt out of research participation); it is hard to decide how well a score received for summarizing/reviewing an article compares with participating with research.

Instructions for Researchers. The following guidelines are put forth for researchers interested in student participation for their studies:

1. All studies available to students must have already been approved by the IRB at Ashoka University.
2. Researchers will provide the Gateway instructor with a brief description of their study and details on student participation (e.g. eligibility criteria, time required for student participation, dates for participating etc.). The description will also include researcher contact information. Until the Department buys SONA systems, the Gateway instructor will share these descriptions and details with students in the first week of classes.
3. Researchers will provide student participants with a debriefing of their study following their participation. The reason underlying this debriefing is to meet the goal of creating an opportunity for students to learn more about psychological research from their participation.
4. In line with the goal of student learning, researchers should be prepared to talk to students about the study/research and answer questions as they see fit.
5. Researchers will keep a record of students participating in their research and send the Research Pool coordinator an email with student participation details by the end of the semester.

² Any sort of relative grading (cluster, curving, etc.) when combined with an extra credit assignment becomes coercive. This is because the extra credit is no longer “extra”, but mandatory.

6. Faculty researchers, research assistants, or research students must sign the student’s Research Participation Sheet at the end of the study (not at the end of the semester). The student needs to submit this sheet to the Research Pool coordinator.

References

Bowman, L. L., & Waite, B. M. (2003). Volunteering in research: Student satisfaction and educational benefits. *Teaching of Psychology, 30*(2), 102-106.

Elicker, J. D., McConnell, N. L., & Hall, R. J. (2010). Research participation for course credit in introduction to psychology: why don't people participate?. *Teaching of Psychology, 37*(3), 183-185.

Sieber, J. E., & Saks, M. J. (1989). A census of subject pool characteristics and policies. *American Psychologist, 44*(7), 1053-1061.

Promotion & Tenure

Publications in Beall’s list of predatory journals (which has been taken off the internet in mid-Jan 2017) will not be counted towards tenure. In fact, publishing in predatory journals could count against tenure, unless these were published long before the candidate was cognizant about scientific standards.

We will consult Joy’s (2006) descriptive statistics to evaluate the research productivity of faculty in tenure or reappointment decisions. His descriptive statistics are imperfect and restricted to universities in northeastern United States, but there are no other normative statistics available.

Career age (years)	Research universities	Other doctoral universities and elite liberal arts colleges	Master’s universities and strong 4-year colleges
1-5	2.63 (2.72)	1.86 (1.90)	0.94 (1.11)
6-10	1.89 (1.00)	1.07 (1.64)	0.56 (0.49)
11-15	2.04 (1.83)	0.97 (0.69)	0.58 (0.71)
16-20	1.81 (1.64)	0.85 (0.71)	0.44 (0.48)
21-25	1.70 (1.04)	0.59 (0.44)	0.37 (0.41)
26-30	2.12 (2.49)	0.91 (0.87)	0.29 (0.49)
30+	1.40 (1.35)	0.84 (0.75)	0.24 (0.30)

Note: Taken from Joy (2006) Table 5.

Ashoka’s psychology program is at its infancy. Hence we should adopt the less stringent criteria in the column “Master’s universities and strong 4-year colleges”. This is because the initial faculty have heavier administrative load and work under constraints. However, this is not to mean that we compromise quality; over time, our criteria must shift ‘upwards’.

The evaluation of the quality of a candidate's research also depends on the impact factor of the journals that the candidate published in. A mindless faith in journal impact factors (JIF) published in Appendix A is unacceptable because, among other reasons, this implies that there is only one correct way of computing 'impact'. In reality, other indices exist, such as the SCImago Journal Rank (SJR; González-Pereira, Guerrero-Bote, & Moya-Anegón, 2010), or SJR2 (Guerrero-Bote & Moya-Anegón, 2012). In general, JIF and SJR correlate well (González-Pereira et al., 2010), but do not succumb to the ecological fallacy; Promotion and Tenure Committees are evaluating a small subset of journals, not a large pool of journals, not the other way around. Furthermore, for some journals, SJR scores diverge substantially from JIF.

Faculty Recruitment

Search Committee

The University requires a Search Committee to be formed in all faculty recruitment. Consult the University's Faculty Handbook for details.

As of 2016, visiting appointments do not require a campus interview; approval from the Head of Department (usually in consultation with colleagues) and Dean is sufficient.

Education and Pedagogy

Ashoka needs to look out for candidates with:

1. TA and Instructor experiences;
2. Experience developing curriculum;
3. Has quality classroom didactics;
4. Experience mentoring research students;
5. Has pedagogical understanding beyond seeing education as merely teaching. Candidates must be able to hold an intelligent conversation about modern university pedagogy.

Research

Ashoka should look for scientists who ask big questions, but are also methodologically sound and scientific in their approach. Impact factors of each publication must be tabulated and these impact factors must be seen in the context of the candidate's field *and* subfield. Predatory journals in Beal's list will not be considered. A candidate may have innocently published in predatory journals early in his or her career. As long as the candidate is no longer doing so, they should be seen in equal standing as any other candidates.

Authorship is important, and in cases where the candidate is not the first author, we must clarify whether the candidate played a mentoring role in that paper. 'Mentorship papers' should be just as highly valued as lead authorship papers because it demonstrates that the candidate is helping to shape the science of the future.

Appendix A is the Journal Citation Reports 2014 from Thomson Reuters for psychology and behavioral science. The list is not meant to be exhaustive. Papers not published in these journals should be well-regarded if the candidate can demonstrate how that paper has contributed to the field.

Invitation for job candidates

From 2015-2018, all job talks have been teaching talks (akin to a keynote address). This gave little opportunity for the department to judge a candidate's research potential. In future hires, candidates may be expected to give both a teaching and research talk.

Many job candidates are used to giving research job talks but struggle with giving teaching demonstrations. They should be made aware that we often seek students' opinions on faculty hires. As

CONFIDENTIAL

such, some candidates may appreciate some advice from us, such as those found below:

Do's	Don't's
<ul style="list-style-type: none">• Invite them to ask questions.• Engage them. Inspire them.• Provoke their thoughts. Get them to think deeply• Do present empirical evidence. From Day 1, students have been trained to be skeptical of theory without data.• Explain the experimental logic if you are presenting empirical evidence.• Create a culture where there's an openness in communication• Bear in mind that 1st year students have taken only Intro Psych and Critical Thinking Seminar, and most 2nd year students have taken Stats/Res Methods, Cog, Dev, Clin, Social. Your talk needs to appeal to both populations; we take their evaluation of candidates seriously• Be careful when you present brain data or psychophysiological data. You have to remember these are at best 2nd year students who don't know why the polarity of ERP's y-axis is reversed, or what the colors of the fMRI brain results actually mean!• Be careful of wagging fingers. We have seen many candidates wag their fingers while giving a teaching demonstration.	<ul style="list-style-type: none">• Do not talk down to them; never shut students off• Do not say "I'll take questions only at the end"; instead welcome questions throughout• Never claim that you know everything; it's ok to admit the limits of your knowledge• Don't neglect explaining the x and y axis. Note the 1st year students haven't had much experience reading graphs like the 2nd year students

Invitation for external candidates

As academics, we enjoy exchanging ideas and host visitors with whom we (would) have a working relationship. But resources are finite, hence we always have three things to consider in any invitation that we send out:

1. Academic: Does the invitation fulfil academic goals?
2. Budget: How much does it cost?
3. Relationship: Are there any long-term relationship between the invitee's university and Ashoka?

These three must balance out, and there is no real formula. To some extent, (3) is the less relevant to us, but more relevant at a Dean and above level (e.g., inviting a Dean of another university over to visit us).

It is not customary to offer any gratuity, but if any gratuity is given, permission must be sought from the HOD before inviting the speaker. As a guide, Stephen Matto quoted an average of Rs 5000 per speaker.

References

- American Psychological Association (2013). *APA guidelines for the undergraduate psychology major*. Washington, D.C.: American Psychological Association.
- Anderson, L. W., & Krathwohl, D. R., et al. (Eds.) (2001). *A taxonomy for learning, teaching, and assessing: A revision of bloom's taxonomy of educational objectives*. Boston, MA: Allyn & Bacon.
- Carnegie Mellon University. (n.d.). Obligations and expectations for undergraduate teaching assistants. https://www.cmu.edu/teaching/resources/PublicationsArchives/UGTA_TAs-v2.pdf
- Bain, K. (2004). *What the best college teachers do*. Cambridge, MA: Harvard University Press
- Bain, K. (2012). *What the best college students do*. Cambridge, MA: Harvard University Press
- Filz, T., & Gurung, R. A. (2013). Student perceptions of undergraduate teaching assistants. *Teaching of Psychology, 40*, 48-51.
- González-Pereira, B., Guerrero-Bote, V. P., & Moya-Anegón, F. (2010). A new approach to the metric of journals' scientific prestige: The SJR indicator. *Journal of Informetrics, 4*, 379-391.
- Guerrero-Bote, V. P., & Moya-Anegón, F. (2012). A further step forward in measuring journals' scientific prestige: The SJR2 indicator. *Journal of Informetrics, 6*, 674-688.
- Hogan, T., Norcross, J., Cannon, T., & Karpiak, C. (2007). Working with and training undergraduates as teaching assistants. *Teaching of Psychology, 34*, 187-190.
- Joy, S. (2006). What should I be doing, and where are they doing it? Scholarly productivity of academic psychologists. *Perspectives on Psychological Science, 1*, 346-364. doi:10.1111/j.1745-6916.2006.00020.x
- McKeegan, P. (1998). Using undergraduate teaching assistants in a research methodology course. *Teaching of Psychology, 25*, 11-14.
- Medawar, P. B. (1979). *Advice to a young scientist*. New York, NY: Harper & Row.
- Stokes, D. E. (1997). *Pasteur's quadrant: Basic science and technological innovation*. Washington, D.C.: Brookings Institution Press.
- Weidert, J. M., Wendorf, A. R., Gurung, R. A., & Filz, T. (2012). A survey of graduate and undergraduate teaching assistants. *College Teaching, 60*, 95-103.

Appendices

A: JCR Impact Factors 2014

Journal	{2014} Total Cites	{2014} Articles	Impact Factor	5-Year Impact Factor
ANNU REV PSYCHOL	13101	27	21.81	26.824
BEHAV BRAIN SCI	7562	20	20.771	24.308
TRENDS COGN SCI	20396	60	21.965	22.5
PSYCHOL BULL	36794	47	14.756	22.155
ANNU REV CLIN PSYCHO	2980	28	12.674	14.369
PSYCHOL REV	24097	26	7.972	11.398
NEUROSCI BIOBEHAV R	16868	198	8.802	10.528
PERS SOC PSYCHOL REV	3862	20	6.692	10.443
CLIN PSYCHOL REV	10297	48	6.932	10.435
PERSPECT PSYCHOL SCI	4439	56	9.546	10.288
PSYCHOL METHODS	7617	31	7.338	9.414
J MANAGE	10823	67	6.071	9.238
ADV EXP SOC PSYCHOL	3566	10	5.318	8.652
J AM ACAD CHILD PSY	17723	96	7.26	8.459
PSYCHOL INQ	2700	6	6.25	8.239
J APPL PSYCHOL	25194	83	4.799	7.753
NEUROPSYCHOL REV	2028	29	4.592	7.531
J PERS SOC PSYCHOL	55364	118	5.031	7.521
SOC COGN AFFECT NEUR	3937	250	7.372	7.332
AM PSYCHOL	17525	55	6.1	7.089
CURR DIR PSYCHOL SCI	6921	71	5.678	6.776
J CONSULT CLIN PSYCH	21076	109	5.279	6.77
J CHILD PSYCHOL PSYC	15504	118	6.459	6.681
PSYCHOL SCI	23416	254	4.94	6.473
COGNITIVE PSYCHOL	6582	32	5.064	6.42

CONFIDENTIAL

PSYCHOL MED	19189	293	5.938	6.336
J EXP PSYCHOL GEN	8281	172	5.929	6.268
CHILD DEV	24293	164	4.061	6.253
PERS PSYCHOL	5432	25	4.49	6.227
J ABNORM PSYCHOL	14289	75	5.153	6.138
DEV REV	2032	15	4	5.958
CLIN CHILD FAM PSYCH	1630	22	3.146	5.865
HEALTH PSYCHOL REV	462	21	6.233	5.833
J CLIN PSYCHIAT	18227	171	5.498	5.818
DEVELOPMENTAL SCI	5700	86	3.808	5.706
ORGAN RES METHODS	3130	18	4.148	5.465
DEPRESS ANXIETY	6059	108	4.407	5.434
DEV PSYCHOPATHOL	8167	102	3.24	5.376
ANN BEHAV MED	4886	80	4.144	5.364
J COGNITIVE NEUROSCI	16870	217	4.085	5.259
J HEALTH SOC BEHAV	6107	30	2.915	5.211
DEV PSYCHOL	17295	248	4.141	5.03
J ORGAN BEHAV	6788	73	3.038	5.017
CORTEX	6768	178	5.128	5.014
AUTISM RES	1209	66	4.33	4.822
PSYCHOSOM MED	11333	86	3.473	4.819
HEALTH PSYCHOL	9083	188	3.59	4.686
COGNITION	13506	164	3.479	4.623
BEHAV RES THER	13847	129	3.395	4.609
J ENVIRON PSYCHOL	4285	97	2.64	4.607
J AUTISM DEV DISORD	13360	285	3.665	4.587
NEUROPSYCHOLOGY	5122	96	3.269	4.447
HORM BEHAV	9250	146	4.632	4.441
COGN AFFECT BEHAV NE	3093	106	3.287	4.415
EMOTION	5705	112	3.383	4.404

CONFIDENTIAL

LEADERSHIP QUART	4979	68	3.138	4.326
PSYCHOL LEARN MOTIV	1427	16	2.964	4.289
ADV STUD BEHAV	1188	8	2.571	4.28
J MEM LANG	7285	68	4.237	4.257
J ABNORM CHILD PSYCH	6681	115	3.481	4.213
NEUROPSYCHOLOGIA	23315	352	3.302	4.178
BEHAV THER	3825	68	3.694	4.151
MULTIVAR BEHAV RES	3905	38	2.477	4.084
J ADOLESCENT HEALTH	10691	235	3.612	4.05
BEHAV RES METHODS	8994	97	2.928	3.968
PSYCHOL AGING	7894	84	2.646	3.949
BIOL PSYCHOL	7167	157	3.403	3.945
J OCCUP HEALTH PSYCH	2001	38	2.458	3.941
ORGAN BEHAV HUM DEC	8268	54	2.201	3.938
NEUROBIOL LEARN MEM	5453	185	3.652	3.914
PSYCHOL ASSESSMENT	7130	130	2.751	3.9
EUR REV SOC PSYCHOL	391	9	2.412	3.881
J COUNS PSYCHOL	5014	61	2.475	3.879
EVOL HUM BEHAV	3202	69	3.13	3.87
FRONT BEHAV NEUROSCI	2195	419	3.27	3.863
J GERONTOL B-PSYCHOL	5686	95	3.213	3.856
AUTISM	2159	96	3.639	3.829
J PERS	6059	48	3.229	3.777
J EXP CHILD PSYCHOL	5648	139	2.549	3.766
EUR CHILD ADOLES PSY	3151	105	3.336	3.742
INTELLIGENCE	3224	120	3.245	3.734
J CLIN CHILD ADOLESC	3808	73	3.312	3.726
PERSONAL DISORD	557	56	3.221	3.713
PSYCHOPHYSIOLOGY	11284	144	2.986	3.696
GENES BRAIN BEHAV	3417	82	3.661	3.662

CONFIDENTIAL

EMOT REV	930	39	3.356	3.653
PSYCHON B REV	8425	180	3.369	3.65
BRAIN LANG	6019	93	3.215	3.637
COMPUT HUM BEHAV	7267	614	2.694	3.624
J BEHAV MED	3478	112	2.959	3.608
J VOCAT BEHAV	5900	84	2.588	3.59
TOP COGN SCI	850	47	3.063	3.563
J EXP PSYCHOL HUMAN	11549	182	3.358	3.562
DEV NEUROPSYCHOL	2874	37	2.241	3.562
J YOUTH ADOLESCENCE	5033	135	2.777	3.546
J EXP PSYCHOL LEARN	11364	130	2.862	3.531
PERS SOC PSYCHOL B	12023	127	2.909	3.527
CHILD DEV PERSPECT	1004	43	3.264	3.489
ARCH SEX BEHAV	4482	145	2.589	3.483
J OCCUP ORGAN PSYCH	2430	37	1.667	3.461
COGNITION EMOTION	5594	109	2.201	3.425
ANIM BEHAV	23456	311	3.137	3.423
EUR J PERSONALITY	2161	44	3.347	3.41
PSYCHOL ADDICT BEHAV	3987	141	2.747	3.404
RES ORGAN BEHAV	2353	11	1.562	3.4
CLIN PSYCHOL-SCI PR	2361	28	1.6	3.391
J ANXIETY DISORD	4895	123	2.594	3.39
J SPORT EXERCISE PSY	2841	50	2.185	3.39
J PEDIATR PSYCHOL	5379	94	2.472	3.38
ASSESSMENT	2317	65	3.108	3.355
BEHAV ECOL	8176	174	3.177	3.35
BRAIN COGNITION	6209	141	2.477	3.335
J ATTEN DISORD	1883	70	3.779	3.327
APPETITE	8728	330	2.691	3.323
J TRAUMA STRESS	5972	102	2.36	3.3

CONFIDENTIAL

BEHAV BRAIN RES	21129	562	3.028	3.298
BRIT J HEALTH PSYCH	1967	53	2.776	3.295
PSYCHO-ONCOLOGY	6751	175	2.443	3.285
BRIT J PSYCHOL	3436	34	2.254	3.277
SOC PSYCHOL QUART	2221	19	1.406	3.276
EXP CLIN PSYCHOPHARM	2466	60	2.712	3.259
INT J EAT DISORDER	6935	119	3.126	3.222
CHEM SENSES	4252	67	3.157	3.199
PHYSIOL BEHAV	18384	331	2.976	3.19
CHILD ABUSE NEGLECT	6741	193	2.574	3.175
J EXP SOC PSYCHOL	7989	132	2.285	3.14
MUSIC PERCEPT	1553	32	2	3.124
CYBERPSYCH BEH SOC N	1396	110	2.182	3.121
J SEX RES	2733	78	2.695	3.103
BEHAV NEUROSCI	7930	68	2.728	3.082
COGNITIVE SCI	3916	64	2.446	3.08
AGGRESSIVE BEHAV	2357	50	2.275	3.077
STRESS	1877	57	2.715	3.05
FRONT PSYCHOL	6105	1244	2.56	3.039
J RES ADOLESCENCE	2135	58	1.915	3.031
ADDICT BEHAV	9199	300	2.764	3.017
J BUS PSYCHOL	1356	47	2.075	3.015
CLIN PSYCHOL PSYCHOT	1591	51	2.632	3.008
ENVIRON BEHAV	3472	41	2.612	3.005
J POSIT PSYCHOL	970	51	1.911	2.987
BRIT J CLIN PSYCHOL	2928	26	2.279	2.982
MONOGR SOC RES CHILD	1922	19	1.966	2.978
PSYCHOL VIOLENCE	251	33	2.368	2.975
PSYCHOL HEALTH	3430	88	1.871	2.932
BEHAV ECOL SOCIOBIOL	10652	195	2.35	2.929

CONFIDENTIAL

INT J PSYCHOPHYSIOL	6171	135	2.882	2.923
BEHAV GENET	3465	53	3.21	2.922
ANIM COGN	2560	131	2.582	2.903
GROUP ORGAN MANAGE	1399	26	1.4	2.869
BILING-LANG COGN	1391	49	2.009	2.862
SOC PSYCHOL PERS SCI	1000	112	2.561	2.856
INFANCY	1404	28	2.086	2.829
J NONVERBAL BEHAV	1207	31	1.974	2.818
REV GEN PSYCHOL	2387	26	1.156	2.8
EARLY CHILD RES Q	2087	65	1.671	2.784
PSYCHOL RES-PSYCH FO	2447	69	2.863	2.76
LAW HUMAN BEHAV	2443	54	2.02	2.759
JUDGM DECIS MAK	1167	47	1.521	2.753
PHARMACOL BIOCHEM BE	13290	254	2.781	2.751
FAM PROCESS	1617	46	3	2.728
J RES PERS	4684	76	2.264	2.723
COGNITIVE DEV	1818	31	2.172	2.717
HUM RESOUR MANAGE-US	1729	46	1.293	2.705
RES AUTISM SPECT DIS	2229	179	2.212	2.7
J SUBST ABUSE TREAT	4214	129	1.996	2.691
BEHAV BRAIN FUNCT	1303	45	1.972	2.684
POLIT PSYCHOL	1972	53	2.384	2.679
J CLIN PSYCHOL	5692	101	2.019	2.677
ACTA PSYCHOL	5246	183	2.248	2.676
BRIT J SOC PSYCHOL	2660	45	1.913	2.675
PSYCHOL AESTHET CREA	623	47	3.054	2.672
AGGRESS VIOLENT BEH	2062	72	1.926	2.668
AM J COMMUN PSYCHOL	4025	72	2.145	2.657
APPL PSYCHOL-INT REV	2165	27	1.984	2.645
J GAMBL STUD	1696	64	2.29	2.639

CONFIDENTIAL

J ADOLESCENCE	3864	155	1.957	2.638
RES LANG SOC INTERAC	740	25	2.897	2.621
EUR J WORK ORGAN PSY	1521	66	2.09	2.615
RES HUM DEV	387	17	1.25	2.613
J BEHAV THER EXP PSY	2262	73	2.312	2.603
J FAM PSYCHOL	4291	102	1.713	2.583
MEM COGNITION	7684	106	2.457	2.577
J CONSUM PSYCHOL	2300	53	2.243	2.561
CHILD PSYCHIAT HUM D	1273	72	2.032	2.551
REHABIL PSYCHOL	1417	53	1.843	2.548
BRIT J DEV PSYCHOL	2100	35	2.841	2.546
PSYCHOL PUBLIC POL L	934	32	1.469	2.539
ATTACH HUM DEV	1199	37	2.127	2.532
ATTEN PERCEPT PSYCHO	2286	196	2.168	2.526
J BEHAV DECIS MAKING	1640	41	2.069	2.526
CONSCIOUS COGN	4098	128	1.941	2.524
SOC DEV	2165	47	1.505	2.524
J DEV BEHAV PEDIATR	3034	59	2.129	2.523
INT J BEHAV MED	1543	115	2.126	2.512
EUR EAT DISORD REV	1458	68	2.461	2.503
APPL PSYCHOL-HLTH WE	256	18	1.757	2.5
BODY IMAGE	1656	78	2.042	2.496
J CLIN EXP NEUROPSYC	4874	93	2.083	2.483
J PERS ASSESS	5017	63	1.837	2.481
CRIM JUSTICE BEHAV	2556	73	1.528	2.481
EXP PSYCHOL	1173	45	2.076	2.475
J APPL DEV PSYCHOL	1837	46	1.185	2.472
PSYCHOL TRAUMA-US	672	99	2.308	2.47
J NEUROPSYCHOL	350	19	2.486	2.465
MEDIA PSYCHOL	840	19	1.1	2.457

CONFIDENTIAL

J EXP PSYCHOL-APPL	1439	31	1.836	2.456
Q J EXP PSYCHOL	4280	149	2.127	2.449
AIDS CARE	5208	243	2.095	2.44
ANXIETY STRESS COPIN	1128	50	1.779	2.434
ARCH CLIN NEUROPSYCH	3049	68	1.986	2.429
SEX ABUSE-J RES TR	985	26	2.113	2.423
BRAIN BEHAV EVOLUT	2138	43	2.013	2.423
CULT DIVERS ETHN MIN	1394	60	1.562	2.391
PSYCHOL SPORT EXERC	1986	88	1.896	2.39
J EARLY ADOLESCENCE	1525	46	1.309	2.39
J COGN DEV	726	39	1.683	2.38
BEHAV PHARMACOL	2782	76	2.148	2.379
PERS INDIV DIFFER	14226	439	1.951	2.378
LANG COGNITIVE PROC	2123	0	2.134	2.377
PSYCHOTHERAPY	1812	56	1.422	2.377
J HAPPINESS STUD	1688	78	1.683	2.364
COGN NEUROPSYCHOL	2293	26	2.073	2.36
MERRILL PALMER QUART	1424	18	1.289	2.355
ARCH SUICIDE RES	773	36	1.385	2.354
HUM DEV	896	15	1.788	2.333
EUR J SOC PSYCHOL	4176	73	1.712	2.333
J PSYCHOPATHOL BEHAV	1695	63	1.759	2.332
FOCUS AUTISM DEV DIS	320	20	1.265	2.33
J HEALTH PSYCHOL	3202	147	1.748	2.319
J CROSS CULT PSYCHOL	3377	101	1.929	2.312
MEMORY	2411	93	1.688	2.289
J COMP PSYCHOL	2776	41	2.344	2.286
INT PSYCHOGERIATR	3758	177	1.934	2.273
PSYCHOTHER RES	1604	57	1.723	2.268
HUM MOVEMENT SCI	3170	132	1.598	2.255

CONFIDENTIAL

BEHAV COGN PSYCHOTH	1333	62	1.905	2.249
J EXP PSYCHOL-ANIM L	2532	40	1.949	2.248
BRAIN BEHAV	368	83	2.243	2.229
PSYCHOL MUSIC	984	54	2.173	2.228
EPILEPSY BEHAV	6400	330	2.257	2.225
APPL ANIM BEHAV SCI	6948	151	1.691	2.225
CLIN NEUROPSYCHOL	2425	77	1.719	2.208
PSYCHOL PSYCHOTHER-T	694	28	1.441	2.188
CHILD CARE HLTH DEV	2532	96	1.692	2.154
PSYCHOL MEN MASCULIN	824	51	1.838	2.147
INT J BEHAV DEV	2508	59	1.316	2.145
APPL ERGON	3629	198	2.023	2.143
PSYCHOL WOMEN QUART	2295	38	1.879	2.142
EUR J PSYCHOL ASSESS	1191	30	1.973	2.124
GROUP PROCESS INTERG	1288	53	1.548	2.118
SOC COGNITION	1951	46	1.532	2.116
APPL PSYCHOPHYS BIOF	828	26	1.847	2.115
J COMP PHYSIOL A	5251	81	2.036	2.103
INFANT BEHAV DEV	2891	78	1.349	2.1
J SOC ISSUES	4454	46	1.529	2.098
AM J DRUG ALCOHOL AB	1949	65	1.779	2.096
BEHAV MODIF	1579	38	1.605	2.083
INT J CLIN HLTH PSYC	513	30	2.85	2.067
SEX ROLES	4970	75	1.735	2.067
THINK REASONING	524	23	2.2	2.062
J POSIT BEHAV INTERV	632	22	1.409	2.06
SELF IDENTITY	871	41	1.514	2.046
CAREER DEV INT	818	40	1.29	2.046
COGNITION INSTRUCT	1249	12	2	2.042
HUM FACTORS	3482	106	1.694	2.037

CONFIDENTIAL

EUR PSYCHOL	861	20	1.778	2.033
EAT BEHAV	1618	129	1.68	2.031
SUICIDE LIFE-THREAT	2560	55	1.853	2.03
LEARN BEHAV	748	34	1.885	2.006
APPL PSYCHOLINGUIST	1723	42	1.512	2.006
PROF PSYCHOL-RES PR	2463	58	1.398	2.006
J SOC CLIN PSYCHOL	2070	48	1.214	2
PSYCHOL RELIG SPIRIT	266	35	1.458	1.983
APPL COGNITIVE PSYCH	3148	98	1.321	1.978
BRIT J MATH STAT PSY	1250	26	2.167	1.954
MOTIV EMOTION	2222	70	1.744	1.954
J TRAUMA DISSOCIATIO	579	32	1.544	1.952
J INTERPERS VIOLENCE	4240	159	1.21	1.95
J MARITAL FAM THER	1231	35	2.528	1.949
J EMOT BEHAV DISORD	846	20	1.659	1.948
COGNITIVE THER RES	3486	59	1.587	1.928
J PSYCHOL	1970	36	1.773	1.925
CRISIS	882	48	1.482	1.923
COUNS PSYCHOL	1595	46	1.252	1.922
J MANAGE PSYCHOL	1508	59	1.2	1.919
PSYCHOL SERV	554	53	1.707	1.918
COGN BEHAV PRACT	1015	38	1.562	1.912
ETHOLOGY	3847	122	1.791	1.895
J CHILD LANG	2146	67	1.598	1.865
J SEX MARITAL THER	1509	40	1.782	1.848
PARENT-SCI PRACT	498	14	1.333	1.848
MIND LANG	939	29	1.089	1.836
INT J HUM-COMPUT ST	2580	63	1.293	1.83
J SOC PERS RELAT	2338	59	1.16	1.826
COGN PROCESS	709	48	1.388	1.818

CONFIDENTIAL

ERGONOMICS	5758	148	1.556	1.804
ASIAN AM J PSYCHOL	208	37	1.686	1.794
EUR J PSYCHOTRAUMATO	299	61	1.602	1.794
J PSYCHOSOM OBST GYN	983	20	1.88	1.788
J APPL SPORT PSYCHOL	1175	32	1.062	1.787
LEGAL CRIMINOL PSYCH	623	23	1.49	1.78
RES Q EXERCISE SPORT	3131	55	1.566	1.778
APPL DEV SCI	838	16	1.536	1.776
J LANG SOC PSYCHOL	785	43	1.02	1.772
J EXP ANAL BEHAV	2907	55	1.865	1.765
SEEING PERCEIVING	152	0	1.324	1.765
J ECON PSYCHOL	2426	72	1.23	1.757
J MENT HEALTH	1240	55	1.57	1.742
J ADOLESCENT RES	1450	30	1.455	1.738
PERS RELATIONSHIP	1613	44	1.366	1.738
SOC PSYCHOL-GERMANY	361	49	1.662	1.736
BEHAV SCI LAW	1581	55	1.449	1.725
AGING NEUROPSYCHOL C	912	34	1.803	1.711
SCAND J PSYCHOL	1908	81	1.057	1.7
ADV CHILD DEV BEHAV	574	20	1.581	1.698
J MOTOR BEHAV	2078	45	1.418	1.695
BEHAV PROCESS	3243	203	1.567	1.689
J CLIN PSYCHOL MED S	822	37	1.212	1.667
BEHAVIOUR	4852	96	1.23	1.652
NEBR SYM MOTIV	668	7	1	1.648
J PERS PSYCHOL	141	20	0.805	1.646
HUM RESOUR DEV Q	579	18	0.833	1.637
J CHILD FAM STUD	1551	133	1.163	1.634
J NEUROLINGUIST	833	32	1.489	1.632
CREATIVITY RES J	1380	50	1.46	1.619

CONFIDENTIAL

SMALL GR RES	1194	28	0.794	1.612
J APPL BEHAV SCI	1055	20	0.914	1.611
BEHAV DISORDERS	573	20	0.848	1.611
AM BEHAV SCI	2669	98	1.766	1.595
I-PERCEPTION	212	29	1.482	1.594
EVOL PSYCHOL-US	609	56	1.389	1.593
J PSYCHOACTIVE DRUGS	1255	53	1.461	1.574
J VET BEHAV	496	56	0.957	1.569
INT J INTERCULT REL	1754	100	1.058	1.558
J COGN PSYCHOL	402	72	1.431	1.555
HUM PERFORM	1142	22	1.273	1.552
PSYCHOL MARKET	2540	85	1.08	1.547
INT J PSYCHOL RELIG	487	20	0.773	1.545
J CAREER ASSESSMENT	819	49	1.507	1.535
J PSYCHOPHYSIOL	803	22	1.59	1.517
EUR J DEV PSYCHOL	552	54	1.721	1.506
NEW DIR CHILD ADOLES	762	5	0.667	1.504
J COMMUNITY APPL SOC	913	37	1.189	1.497
J ECT	1230	53	1.389	1.494
J INDIVID DIFFER	343	27	1.222	1.489
ECOL PSYCHOL	740	24	0.842	1.488
INFANT CHILD DEV	889	44	1.179	1.487
BEHAV MED	594	17	1	1.484
EARLY EDUC DEV	814	61	0.765	1.477
CAN PSYCHOL	864	34	1.825	1.475
DISCOURSE PROCESS	1228	28	0.887	1.472
CAN J EXP PSYCHOL	918	26	1.218	1.467
SOC JUSTICE RES	731	23	1.17	1.466
INT J COGN THER	270	22	0.661	1.448
PERS REV	913	46	0.921	1.438

CONFIDENTIAL

NEW IDEAS PSYCHOL	508	28	1.444	1.405
PSYCHOSIS	173	37	1.446	1.39
J COMMUNITY PSYCHOL	2103	68	0.667	1.388
J FAM VIOLENCE	1731	85	0.748	1.379
PERCEPTION	5022	108	0.906	1.371
SPORT PSYCHOL	1068	32	0.882	1.371
J PSYCHOSOC ONCOL	691	42	1.22	1.367
J HOMOSEXUAL	1408	80	0.953	1.364
J APPL BEHAV ANAL	3590	81	1.088	1.36
GROUP DYN-THEOR RES	736	22	1.214	1.359
AM INDIAN ALASKA NAT	183	6	1	1.349
LANG SPEECH	1067	24	1.04	1.348
LATERALITY	702	43	1.356	1.335
LEARN MOTIV	1055	19	1.436	1.333
PSYCHOL BELG	262	24	0.659	1.323
EUR J PSYCHOL APPL L	68	11	1.45	1.314
CHILD ADOL MENT H-UK	474	40	1.441	1.314
COGN SYST RES	408	19	0.831	1.311
PSYCHOL CRIME LAW	853	59	1.063	1.29
J SOC PSYCHOL	2125	45	0.981	1.257
DEATH STUD	1165	79	0.774	1.253
SPAT COGN COMPUT	242	12	0.857	1.25
DISCOURSE SOC	1002	36	0.71	1.25
PSYCHOL REC	997	78	0.879	1.24
INT J OFFENDER THER	985	95	1.014	1.237
CAN J BEHAV SCI	893	53	1.015	1.234
J REPROD INFANT PSYC	693	38	0.723	1.233
J LOSS TRAUMA	417	41	0.707	1.233
MEAS EVAL COUNS DEV	542	21	0.462	1.233
INT J PSYCHOL	1374	66	1.198	1.229

CONFIDENTIAL

DIAGNOSTICA	745	16	1.057	1.219
INFANT MENT HEALTH J	1328	55	1.071	1.215
THEOR PSYCHOL	720	43	0.906	1.214
KINDH ENTWICKL	315	27	1.526	1.2
INT J SELECT ASSESS	1008	38	0.814	1.199
COGN BEHAV NEUROL	620	27	0.946	1.189
AUST J PSYCHOL	607	28	0.719	1.188
BASIC APPL SOC PSYCH	1321	49	1.019	1.168
INT J CLIN EXP HYP	539	27	0.673	1.156
ETHOS	557	24	0.905	1.143
J INVEST PSYCHOL OFF	168	16	0.8	1.134
HISPANIC J BEHAV SCI	1136	28	0.627	1.125
CHILD YOUTH CARE FOR	354	44	1.086	1.124
DEVIANT BEHAV	743	58	0.942	1.12
J BLACK PSYCHOL	633	25	0.854	1.12
J CHILD SEX ABUS	488	57	0.807	1.112
ADAPT BEHAV	465	26	0.859	1.107
PSICOTHEMA	1592	75	1.21	1.097
AUST PSYCHOL	592	39	0.753	1.093
INT J SPORTS SCI COA	368	141	0.48	1.087
CULT PSYCHOL	484	30	0.956	1.081
HUMOR	395	30	0.481	1.061
CHILD FAM BEHAV THER	298	12	0.471	1.061
J ETHOL	725	22	0.97	1.06
MIND BRAIN EDUC	228	22	0.984	1.059
J THEOR SOC BEHAV	670	23	0.756	1.055
J APPL SOC PSYCHOL	5280	75	0.79	1.049
J FAM THER	432	25	1.151	1.04
ACTA ETHOL	279	27	1	1.039
J EDUC MEAS	938	24	0.922	1.025

CONFIDENTIAL

PSYCHOTHER PSYCH MED	685	57	1.121	1.022
J GENET PSYCHOL	1006	34	0.694	1.015
ETHOL ECOL EVOL	706	25	1.103	1.013
INT J SPORT PSYCHOL	729	27	0.485	1.013
PSYCHOL RUNDSCH	202	15	1.097	1
J DUAL DIAGN	178	28	1.044	1
MUSIC SCI	282	27	0.809	1
ANAL SOC ISS PUB POL	274	27	0.532	1

SOC INFLUENCE	244	20	0.795	0.98
BEHAV ANALYST	299	13	0.4	0.978
J CAREER DEV	387	28	0.891	0.976
AM J PSYCHOL	2229	35	0.619	0.976
CLIN PSYCHOL-UK	124	13	0.933	0.973
J ORGAN BEHAV MANAGE	374	21	0.486	0.967
SWISS J PSYCHOL	259	25	0.778	0.939
PERSONAL MENT HEALTH	150	29	0.738	0.935
TEACH PSYCHOL	726	56	0.667	0.935
J GEN PSYCHOL	913	22	0.605	0.933
J DIVERS HIGH EDUC	143	18	0.829	0.927
FEM PSYCHOL	510	28	0.8	0.92
SPAN J PSYCHOL	724	55	0.586	0.92
PSYCHOANAL PSYCHOL	479	30	0.741	0.904
INT J AGING HUM DEV	976	28	0.391	0.897
J COUNS DEV	1283	50	0.545	0.892
ASIAN J SOC PSYCHOL	536	31	0.623	0.89
OMEGA-J DEATH DYING	662	36	0.414	0.885
CAREER DEV Q	548	23	0.533	0.844
CURR PSYCHOL	514	42	0.429	0.842
ORGAN DYN	1251	34	0.789	0.841
BEHAV INTERVENT	374	23	0.718	0.841

CONFIDENTIAL

INT J SEX HEALTH	140	24	0.708	0.838
BEHAV CHANGE	330	18	0.595	0.826
AM J CLIN HYPN	331	20	1.152	0.824
MIL PSYCHOL	468	31	0.302	0.808
SEX RELATSH THER	341	32	0.714	0.804
INTEGR PSYCHOL BEHAV	350	29	0.7	0.798
INT J EDUC VOCAT GUI	126	18	0.654	0.797
J ADULT DEV	357	22	0.69	0.789
PHILOS PSYCHOL	492	48	0.784	0.787
IND ORGAN PSYCHOL-US	589	83	0.579	0.782
J COLL STUDENT DEV	1111	63	0.336	0.782
MULTISENS RES	26	23	0.781	0.781
J PSYCHOLINGUIST RES	973	46	0.633	0.772
TER PSICOL	140	24	0.903	0.746
BEHAV PSYCHOL	250	32	0.826	0.739
HIST PSYCHOL	149	22	0.688	0.725
EUR REV APPL PSYCHOL	317	36	0.677	0.721
J CONSTR PSYCHOL	245	21	0.565	0.707
ART PSYCHOTHER	447	69	0.541	0.696
BRIT J GUID COUNS	396	40	0.453	0.695
PERCEPT MOTOR SKILL	4962	139	0.546	0.689
ETHICS BEHAV	390	34	0.444	0.676
KOLNER Z SOZIOL SOZ	424	24	0.667	0.656
REV PSICOL DEPORTE	280	54	0.487	0.654
DREAMING	275	23	0.625	0.644
AN PSICOL-SPAIN	405	122	0.504	0.634
AM J FAM THER	400	33	0.525	0.622
J MULTICULT COUNS D	304	16	0.432	0.609
PSYCHOL REP	4532	142	0.56	0.592
J COGN BEHAV PSYCHOT	95	0	0.367	0.59

CONFIDENTIAL

GEDRAG ORGAN	127	20	0.375	0.587
J PSYCHOL THEOL	304	30	0.288	0.583
INFANT YOUNG CHILD	339	22	0.239	0.582
JPN PSYCHOL RES	264	34	0.5	0.576
PSICOLOGICA	184	20	0.441	0.564
S AFR J PSYCHOL	414	41	0.473	0.56
J HUMANIST PSYCHOL	298	23	0.267	0.521
NORD PSYCHOL	74	19	0.256	0.5
J PAC RIM PSYCHOL	36	11	0.25	0.5
SOC BEHAV PERSONAL	1285	162	0.366	0.488
INT J GROUP PSYCHOTH	227	28	0.291	0.481
PSYCHIAT PSYCHOL LAW	296	62	0.462	0.477
INFANC APRENDIZ	203	28	0.317	0.464
STUD PSYCHOL	160	24	0.442	0.462
J FORENSIC PSYCHOL P	107	24	0.42	0.442
ARCH PSYCHOL RELIG	73	17	0.472	0.433
J ANAL PSYCHOL	175	35	0.6	0.43
PSYCHOLOGIST	362	55	0.538	0.419
REV PSICOL SOC	136	21	0.286	0.419
ESTUD PSICOL-MADRID	74	33	0.468	0.402
PRAX KINDERPSYCHOL K	218	41	0.383	0.399
ANN PSYCHOL	334	20	0.44	0.397
INT J AVIAT PSYCHOL	425	17	0.275	0.396
J EMPLOYMENT COUNS	155	14	0.375	0.376
REV LAT AM PSICOL	144	23	0.205	0.365
PSYCHOL FR	114	23	0.317	0.343
PSYCHOTHERAPEUT	232	56	0.316	0.335
PSIHOLOGIJA	71	28	0.232	0.333
GRUPPENPSYCHOTHER GR	73	15	0.41	0.306
INT REV RES DEV DISA	18	14	0.161	0.286

CONFIDENTIAL

REV ARGENT CLIN PSIC	54	24	0.098	0.285
REV MEX PSICOL	87	20	0.257	0.267
PRAT PSYCHOL	60	18	0.333	0.23
CESK PSYCHOL	125	44	0.239	0.23
PSICOL-REFLEX CRIT	201	88	0.147	0.204
J PSYCHOL AFR	112	74	0.161	0.18
PSYCHOLOGIA	183	9	0.256	0.168
REV INT PSYCHOL SOC	90	21	0.1	0.133
REV IBEROAM DIAGN EV	27		0.15	0.129
PSIKHOL ZH	11	52	0	0.01
PSYCHOL SCI PUBL INT	685	4	16.833	N/A
INT REV SPORT EXER P	227	12	4.526	N/A
MINDFULNESS	535	69	3.692	N/A
ADV COGN PSYCHOL	277	15	1.646	N/A
EAT DISORD	673	32	1.484	N/A
FIRST LANG	583	28	c	N/A
J RATION-EMOT COGN-B	296	24	1.294	N/A
SOC ISS POLICY REV	137	7	1.214	N/A
J NEUROSCI PSYCHOL E	124	16	1.121	N/A
SCH MENT HEALTH	177	22	1.098	N/A
CLIN CHILD PSYCHOL P	738	40	1.025	N/A
INT J MENT HEALTH AD	489	59	0.992	N/A
J MEDIA PSYCHOL-GER	200	18	0.882	N/A
INT J STRESS MANAGE	751	19	0.853	N/A
EMPIR STUD ARTS	56	14	0.32	N/A
CLIN CASE STUD	140	34	0.279	N/A
NEGOT CONFL MANAG R	80	16	0.25	N/A
ANNU REV ORGAN PSYCH	7	23	N/A	N/A
LANG COGN NEUROSCI	38	100	N/A	N/A

CONFIDENTIAL

Notes: Table is sorted by 5-year impact factor. The impact factors are $M = 2.06$, $SD = 2.25$ (2014), and $M = 2.60$, $SD = 2.64$ (5-year), and the median impact factors are 1.59 (2014) and 2.07 (5-year). The correlation between the 5-year impact factor and impact factor for 2014 is $r = .98$. Because homoscedacity assumption may be violated, both impact factors were log-adjusted, and the log-adjusted correlation was $r = .96$. Dotted lines indicates the cutoff at impact factor = 1. See Appendix B.

D: Research Requirement (RP pool front-end policy)

To meet the research experience requirement, you must complete 1.5 credit hours of research experience using one of the following two options:

Option A: Participate in Department of Psychology faculty-led research

Option B: Summarize an empirical psychology article.

All PSY101 students are required to complete this requirement.

Why do we have this requirement as part of PSY101?

A key learning objective of PSY101 is for students to gain an understanding of psychology as a science. An exciting way to learn about psychological research is to engage in psychological research firsthand! By participating in research, you will be able to learn more about the different types of research conducted by the psychology faculty at Ashoka. In addition, you will be able to learn about psychological research from a participant's perspective. We encourage you to try and participate in research to meet this requirement as far as possible, and to review an empirical paper if you are not able to or do not want to participate in research.

In the sections that follow, the requirements for research participation and review of an article are outlined. Please read over these sections carefully:

What is the research requirement for PSY101?

- You need to complete a total of 1.5 research credits to meet the requirement for this course. One hour of research participation is worth 1 credit. If a particular research lasts half hour, you get 0.5 credits, which is the minimum (i.e., even a 15-min experiment is worth 0.5 credits).
- If you choose not to participate in research, you will need to complete a review of a research article for 1.5 credits

Besides earning research credits, will I be rewarded in any other way for participating in a research study?

- Some studies do give rewards to participants (e.g., money), but some do not. This depends very much on the study itself.

How do I participate in research?

- A list of available options of studies is shown on our course website. The list may be expanded (e.g., new studies come onboard) or shrink (e.g., an researcher has gathered enough data) as the semester progresses, so do check from time to time.

CONFIDENTIAL

- You can review the study details and the requirements to participate and sign up for participation accordingly. Please note that the studies listed here have received the approval of the Ashoka University Institutional Research Board (IRB).
- Please do not sign up for to participate in a study and miss your appointment! In case you have signed up for a study and need to cancel, please contact the researcher at least 24 hours before your assigned time.

What are the guidelines for reviewing articles?

- If you choose this option, please do the following:
 - Choose a research article (not a review article) in psychology. It is important to know the difference between a review article and a research article. One way to do this is by looking for a study referenced in your textbook. Alternatively, you can look through psychological journals to select your article. Make sure your article includes original research carried out by the authors. The article should include clear method and results sections.
 - Write a two-page review (excluding the title page and reference list) of the article. The review should include a description of hypotheses, research method, results, and conclusion. Make sure to end with a short analysis (i.e. what you got out of the article). You may not understand the statistics reported in a results section, but you should still be able to understand what the research found.
 - Your submission should include a title page with your full name, semester, year, course number.
 - The paper must be typed and double-spaced. You must use Times New Roman font with a 12-point font size. All margins must be 1". The paper should be sent as a Word document. Please make sure to meet these guidelines to get the credit for your submission.
 - Attach a copy of the article you have summarized (doc or .docx format) at the end of your write-up.
 - Please make sure your summary is written in your own words and not copied from the article. Plagiarism is a serious academic offence.
 - Print and submit your summaries by Apr 29 at a mailbox marked "Research Participation Form/Research Summaries" outside Rm 608 (Admin Block).
 - Each report will be graded as Satisfactory (S = 1.5 credit) or Unsatisfactory (US = 0 credit) at the end of the semester.

When do I participate in research/meet the requirement?

- The deadline for completion of the requirement is Sunday, April 29 by 11:59pm. This is a firm deadline. We strongly encourage you to complete this requirement earlier in the semester. It is very likely that there might not be enough studies or research time slots for you towards the end of the semester. Furthermore, even though this requirement may not seem like a lot of work right now, it will add to your workload with finals and course assignments more so at the end of the semester.

What do I do after I participate in each experiment?

CONFIDENTIAL

- You will be given a Research Participation Form at the beginning of the semester. You should get the faculty researcher, research assistant, or research student to sign off this sheet whenever you participate in his or her study.
- At the end of the semester, or whenever you have completed your research participation requirements, drop the form off at a mailbox marked “Research Participation Form/Research Summaries” outside Rm 608 (Admin Block).

What happens if I do not meet the research experience requirement?

- The research experience is an important component of the educational experience for PSY101. If you do not meet this requirement by the deadline indicated, your grade will drop as follows:

Completed the 1.5 credits research requirement — no drop in grade

Completed 1 credits — half a level drop in final grade (i.e. A to A-; B+ to B)

Completed .5 credits — 1 level drop in final grade (i.e. A to B; B+ to C+)

Completed 0 credits — 1.5 level drop in final grade (i.e. A to B-; B+ to C)

E: PhD Programme in Psychology

The Department of Psychology at Ashoka University invites application for its PhD program (Monsoon 2019) in cross disciplinary research spanning different domains of psychology. Our faculty expertise spans social, developmental, biological, cognitive, clinical and counseling psychology. Methodologies span qualitative and quantitative, theoretical and experimental. Prospective students are requested to visit the faculty webpages to find out more about individual faculty research and contact faculty prior to their formal application. Please read through the instructions carefully before proceeding with applications.

PhD Coordinators for the department of psychology: Dr. Simi Ghosh (simi@ashoka.edu.in), Dr. Prakash Padakannaya (prakash.padakannaya@ashoka.edu.in)

Eligibility

Master's Degree or equivalent (M.Tech or MPhil) in Psychology, Neuroscience, Cognitive Science, Biology, Life Sciences, Computer Science, Mathematics, Statistics, Economics, Social Science, Political Science, Philosophy, Literature, Law, or allied disciplines. Applications from candidates with MBBS, or B.Tech./B.E. will also be considered eligible. All candidates need a minimum score of 55% in their respective degrees.

We are particularly looking for candidates who have a passion for research, who are highly motivated and can create and take forward their own ideas in research. We value candidates who enjoy collaboration and forging work with a sense of team spirit.

Documents required:

- Full, up to date CV
- Three letters of recommendation
The letters should be from current or former professors, academic/ professional advisors or supervisors who know your academic work and/or are in a good position to assess your professionalism, aptitude towards research, individual strengths and weaknesses.
- Personal statement (1000-1500 words)
Prior to writing the essay, please visit the program website and faculty webpages to know what sort of research is being pursued in the department prior to writing your statement. In your statement, you should identify at least 2 faculty members whose work might interest you, and who could become your prospective thesis advisor.

Use this essay to state what draws you to research with emphasis on your reasons of interest in the Psychology PhD program at Ashoka University. In addition you might want to consider these questions: How do you think your academic background is related or ties into the research you want to conduct? What kind of research do you want to conduct, in broad terms at the Department of Psychology at Ashoka University? Who are the two faculty members who can become your prospective thesis advisor(s)? What skill sets and experiences do you have already that can help you attain your research goals? How can the program help you attain the goals, and what do you hope to learn?

In addition, you may give the admissions committee any information about your life, your long term and short term career goals or anything else that you deem crucial for the committee to know, in order to make a decision on your application.

CONFIDENTIAL

- One original sample of academic writing
This can be your undergraduate or master's thesis, a project report, a term paper that you wrote for a course. The work has to be completely original, and will be checked for evidences of plagiarism. Any plagiarism detected can lead your application to be summarily rejected.

Prospective applicants are advised to consult these books before preparing their application materials:

American Psychological Association (Ed.). (2007). *Getting in: A step-by-step plan for gaining admission to graduate school in psychology*. Washington, DC: American Psychological Association.

Keith-Spiegel, P., & Wiederman, M. W. (2000). *The complete guide to graduate school admission: Psychology, counseling, and related professions*. New York, NY: Psychology Press.

Procedure of selection and admission

Ph.D. admission will be based on a written test at the Ashoka University campus in Sonapat, followed by a personal interview.

Timeline

For admission in Monsoon 2019, applications will open on **December 1, 2018** and close on **February 28, 2019**. The admission test and interview will be conducted in **April, 2019**. The specific dates and schedules will be released in **March, 2019**.

The duration, number of questions and weightage of the sections included in the admission test will also be released at this time. Candidates are requested to carefully go through the syllabus and prepare accordingly.

Names of the applicants accepted for admission will be uploaded on the PhD page of the program website (accepted and waitlisted etc.) through **May 2019**.

When the name of the candidate appears on the website as selected, **the candidate has one month to accept or decline the admission offer**. The program will consider an offer declined if we don't hear back via email from the accepted applicant within one month. In case of a wait list, the program will then consider those applicants. Applicants will be expected to arrive and settle when Monsoon semester starts, which is usually in the last week of August.

Structure of the admission test

The test will have two sections. The first section is mandatory for all applicants. It will test their general aptitude, basic analytical skills, understanding of academic integrity and ethical practices in research, and statistical literacy.

Syllabus for the first section:

Numerical abilities: Grade 10 mathematics as per CBSE/ICSE/International school boards

Academic integrity and research ethics: What is academic integrity and why is it required?

What is plagiarism (including self-plagiarism)? Citing, summarizing, paraphrasing and quoting others' work.
<https://usingsources.fas.harvard.edu/>

Responsible conduct of research: For any epidemiological/intervention based/ investigative/observational studies involving humans: <http://www.who.int/ethics/research/en/>

For animal research: <https://www.aaalac.org/accreditation/RefResources/IGP2012.pdf>

CONFIDENTIAL

Statistics: Empirical methods in science, constructs and their operationalization into variables, continuous and discontinuous variables, scales, reliability and validity, frequencies, distributions, central tendencies: Mean, median, mode; measures of dispersion; graphical representation of data; correlation and covariance; standard normal distribution; sampling error of the mean and standard error; hypothesis testing; Type I and Type II errors; t-tests; chi square test; ANOVA (all types, including post hoc tests and corrections); and regression (simple and multiple); non-parametric statistics; confidence intervals, power analysis, and effect size.

Rather than mathematical derivations and formulations, questions will test applied aspects of these statistical concepts. You will be tested on

- 1) Your ability to interpret graphical data
- 2) Spot data inconsistencies and errors on graphical representations
- 3) Understanding of errors that compromise reliability and validity of a study
- 4) How to operationalize constructs into variables
- 5) What sort of experimental designs merit which kind of statistical tests to be applied
- 6) Interpreting test scores and what can you conclude about experimental results from statistical testing of data

A good resource to prepare apart from any college level statistical course material: <http://onlinestatbook.com/>

Statistical skills involving latent variable modeling (in various forms), meta-analysis, and time series analysis will not be tested.

The second section will be grouped into six subsections out of which candidates will choose any four. Questions will be grouped according to the core domains in psychology: Biological, Developmental, Clinical, Social, Cognitive and Measurements and Methodologies. This section will follow the syllabus of the subject GRE test in psychology. Please use the following link to obtain the syllabus and sample questions.

https://www.ets.org/s/gre/pdf/practice_book_psych.pdf. The following textbook might provide a good starting point for preparation:

Passer, M. W., & Smith, R. E. (2004). *Psychology: The science of mind and behavior* (2nd ed.). New York, NY: McGraw-Hill.

There are also several commercially available study guides which can help you prepare for this part of the test regardless of your academic background.

Programme structure

The PhD programme trains the next generation of rigorous, confident, responsible, and competent scholars who will address important problems, problems where the answer matters to science in particular, or to humanity in general (Medawar, 1979, *Advice to a Young Scientist*).

Accepted students are expected to commit full-time to their PhD studies. They are not allowed to take on paid jobs outside their studies, unless it can be demonstrated that these jobs contribute to their research. They are expected to spend no less than 40 hours a week, for 51 weeks annually. Candidates should know that it is not uncommon to spend 70 hours a week working towards their degree.

General structure of the PhD Program: The PhD program will include academic and research training as well as ethical and career development training. The first two years (one year, in case of M.Phil/M.Tech entrants) will be heavily tilted to coursework and professional development and career planning workshops. From third year onwards, gradually the research components will start to predominate, and years 4 and 5 will be more or less research centric. Three activities will be mandatory for all PhD students through their tenure at the Department of Psychology at Ashoka University.

CONFIDENTIAL

1. **Psychology Journal Club:** Every week a student will present a journal article. Attendance is mandatory for all PhD students. Senior students will present in the earlier part of the academic year for the newer entrants to learn from their peers
2. **Graduate research seminar in Psychology:** Every week two students will present their own research in front of the department. Attendance is mandatory for all PhD students and all faculty members are encouraged to attend the weekly GRS
3. **Teaching assistantships:** Each student will serve as graduate TAs in a course in consultation with the thesis advisor every semester starting from the beginning of second year. The particular arrangements will be worked out by the advisor and the department on a case by case basis.
4. **Individual Development Plan(IDP):** Every year, starting from the first year, students will submit an individual development plan to the PhD coordinator and the advisor by **October 1 of every academic year**. This will serve as a roadmap to the upcoming year for the student, and will be reviewed as part of their annual progress review. Further resources on how to think about an IDP is available online and some guidelines are provided below. The students will receive more guidance on this as they enroll in the program

Duration of the PhD program: For candidates with M.Phil or M. Tech, the duration of the PhD Fellowship is 4 years. For every other entrant, the duration of the PhD fellowship is 5 years. The PhD curriculum has been developed within this framework.

Tentative guidelines are provided below for structuring each year of the PhD Program

Between selection and enrollment

- After the students have been selected for admission, they will actively correspond with the potential thesis advisors and finalize this by a process of mutual agreement. This should be completed as soon as possible but no later than July 1, 2019 for a September 2019 admission.
- Familiarize yourself with the proposed project(s) you will be working on for the first two years of your PhD. One of these could potentially become your dissertation project.
- Using the time between selection and enrollment, the prospective student is encouraged to think and formulate a plan for their tenure at Ashoka University. Sample but not exhaustive pointers to think about could be
 - What are your strengths? (academically, and non-academically) How will these strengths become complementary to your advisor's expertise for the project(s) discussed? How well do you fit in to the research group?
 - What are your weaknesses? (academically and non-academically). How can you improve yourself in these areas using the resources and the PhD experience at Ashoka University?
 - How well do you understand ethical issues for responsible conduct of research and academic integrity? If there are gaps, which areas do you need to address first?
 - What are your short term and long term goals? How can the PhD Program at Ashoka University help you attain those?
 - What parallel skills can the program give you in addition to theoretical and technical expertise directly related to your PhD program?

All these will be essential in writing your Individual Development Plan (IDP) at the very beginning of year 1 and every subsequent years. This is a program requirement and cannot be waived for any student.

Year 1 (25 credits)

CONFIDENTIAL

1. Deadline to declare primary advisor (s) : **September 15**
2. **Monsoon Semester:**
 - a. One Core Course (4 Credits), One elective course (4 credits) or 2 Core Courses (4 + 4 = 8 credits) or 2 electives (4 + 4 = 8 credits)
 - b. Psychology Journal Club = 1 Credit
 - c. Graduate Research Seminar = 1 Credit
 - d. Research activities = 2 or 3 Credits

Spring Semester:

- a. One Core Course (4 Credits), One elective course (4 credits) or 2 Core Courses (4 + 4 = 8 credits) or 2 electives (4 + 4 = 8 credits)
- b. Psychology Journal Club = 1 Credit
- c. Graduate Research Seminar = 1 Credit
- d. Research activities = 2 or 3 Credits

Based on the student's background, the advisor and the student will determine a set of courses (core or elective) the student needs to take during years 1 and 2, and possibly additional courses in latter years if these courses are relevant. The availability of courses, the nature of the proposed PhD project, and the prior training of the student will all decide the exact nature of the courses the student will pursue.

3. Student training will involve statistical training, data analysis, research design, scientific writing, citations, presentation, management and dissemination of data (including issues concerning data privacy, data protection, data ownership, and intellectual property rights), and programming. These are mandatory.
4. All students will take coursework on ethical practices in social science and behavioral research. Unless a centralized ethics course is created, thesis advisor will take this responsibility to train students on matters of ethics.
5. Through years 1 and 2 students will also gather preliminary data in order to write their thesis proposal documents.
6. Students will submit an individualised development plan (IDP) by **October 1 to the advisor and the PhD Coordinator**. At the annual review, the IDP will be followed up on. For details on how to write an IDP students will receive guidance once admitted
7. Annual review will be conducted with collaboration with the mentor and submitted to the graduate coordinator no later than **May 28, 2019**.

Year 2 (25 Credits)

Monsoon Semester:

- a. One Core/ elective/ methodology Course (4 Credits)
- b. Psychology Journal Club= 1 Credit
- c. Graduate Research Seminar = 1 Credit
- d. Teaching assistantship = 1 credit
- e. Research activities = 1 or 2 Credits
- f. Mandatory workshops (1 X 4 = 4 credits)
 - i. Research ethics and academic integrity
 - ii. Laboratory safety and occupational hazards / field ethical issues
 - iii. Reading for your literature review. Primary literature searching using databases, collating search, creating a bibliography and maintaining, updating citations

CONFIDENTIAL

- iv. Handling and collection of Data-I (proper record keeping, data privacy, data protection, data ownership, and intellectual property rights)

Spring Semester:

- e. One Core/ elective/methodology Course (4 Credits)
- f. Psychology Journal Club= 1 Credit
- g. Graduate Research Seminar = 1 Credit
- h. Teaching assistantship = 1 Credit
- i. Research activities = 1 or 2 Credits
- j. Mandatory Workshops (1 X 4 = 4 Credits)
 - i. Programming I
 - ii. Handling and collection of data- II (Statistics)
 - iii. Scientific Writing (Writing a research review)
 - iv. Scientific Communication (Good presentation skills, effective ways to deliver concepts, speaking to a lay audience versus an expert audience)

The Psychology PhD qualifying exam

The purpose of the qualifying exam is to judge whether the student has enough theoretical knowledge and grasp of primary literature in his/her field of research, and is adequately poised to launch a dissertation project. This examination will be on a descriptive format and will be spread over both semesters of the second year. The monsoon semester will be devoted primarily to reading and understanding the literature and identifying pertinent research questions and the spring to articulately summarizing current research and writing them in the form of a series of mini reviews.

- a) **By September 30th** of academic year 2, PhD students will identify a three to four member committee consisting of both internal and external faculty members. (Advisor is a part of the thesis committee). The names and details of the committee members should be forwarded to the PhD coordinator via email, using the prescribed format.
- b) At the beginning of the monsoon semester, the student will choose a topic of interest allied to the intended dissertation project. Submission deadline for chosen topic to the : **October 15th**
- c) Each student will conduct a comprehensive literature review on the selected topic and create a bibliography of not less than 75 references. Not more than 5-6 of these should be review articles. Rest should be primary literature. Based on the readings, the student will identify 4-5 existing research gaps in the literature, and write 4-5 questions.
- d) A final list of 4-5 questions should be submitted to the committee members by December 1, with the entire bibliography via email
- e) The committee can keep the questions submitted intact, modify them, add their own or completely change the questions.
- f) **By December 15** students will receive the final version of the questions back from the committee.
- g) The students will write the answers to the questions that the committee returned back to them. Each answer should be formatted like a minireview and organized in to subheaders, with a reference section of its own. The submission deadline is **March 31** (Spring semester, academic year 2).
- h) The committee members will review the answers and return an answer via email through the student's advisor whether the student has passed the qualifying exam, will be graded a pass contingent on major or minor edits or has failed the qualifying exam.
- i) Any student who has been graded a fail, or has been suggested edits, has till **May 1** to rewrite the answers.
1. If the student's progress is unsatisfactory by the end of their second year, or the student is unable to pass the qualifying examination, they will be asked to leave the programme. In exceptional cases (e.g., pregnancy), they may be granted an extended probation period of not more than 12 more months. Annual review must be submitted in the prescribed format to the PhD coordinator by **May 28**.

Year 3

CONFIDENTIAL

2. Monsoon Semester:

- a. One advanced methodology/elective Course (4 Credits)
- b. Psychology Journal Club = 1 Credit
- c. Graduate Research Seminar = 1 Credit
- d. Teaching assistantship = 1 credit
- e. Research activities = 1 or 2 Credits
- f. Mandatory workshops (1 X 4 = 4 credits)
 - i. Writing a research proposal
 - ii. Programming II
 - iii. Dissemination of data (How to make up composite figures for presentation and publication, how to create quality posters for research conferences)

Spring Semester:

- k. Psychology Journal Club= 1 Credit
- l. Graduate Research Seminar = 1 Credit
- m. Teaching assistantship = 1 Credit
- n. Research activities = 1 or 2 Credits
- o. Mandatory Workshops (1 X 4 = 4 Credits)
 - i. Handling and collection of data- III(Statistics)
 - ii. Programming = III
 - iii. Telling an academic story: Qualitative methods
 - iv. Pedagogical practice = I

Psychology Thesis proposal:

1. **By November 15th** of their third academic year, students will submit the first draft of their thesis proposal document, styled as an APA project proposal to their thesis committee. The students will be encouraged to turn this proposal to a funding application from external sources.
2. By the end of the semester students will present their thesis proposal defense followed by a closed examination with the thesis committee. On passing the proposal defense, students will advance to PhD candidacy and be registered for a PhD. Following the thesis proposal, student should schedule biannual committee meetings with the thesis committee to track progress until the defense of the thesis.
3. Depending on the opportunity and funding, students may apply to be a visiting scholar at another university for a limited period of time. The learning outcomes of such visiting positions must be discussed with their advisor(s).

Years 4 and 5 (25 credits each)

4. Year-long activities spanning both semesters
 - a. Psychology Journal Club= 1 Credit (4)
 - b. Graduate Research Seminar = 1 Credit (4)
 - c. Teaching assistantship = 1 Credit (4)
 - d. Research activities = 30 Credits (three 8 credits and one six credit semester)
 - e. Mandatory Workshops (1 Credit each) (8)
 - i. Pedagogy II and III
 - ii. Programming IV
 - iii. Effective conference strategies
 - iv. Thesis writing I & II
 - v. Effective academic job search strategies, Writing research and teaching philosophy statements

CONFIDENTIAL

- vi. Alternative careers for PhDs
- vii. Writing good grants
- viii. Additional ethical training
5. The students will be expected to present their research in reputable national and international conferences, symposia and meetings in the field, contingent to applying and obtaining funding support from appropriate bodies
6. Students are expected to publish their research in peer reviewed journals that are internationally reputable. Bear in mind that non-internationally reputable outlets will not be considered, and might even work against you in your career. At least one article accepted, in press, or published is highly recommended before a thesis defense is scheduled. Students should note that publications in other forms (e.g., book chapters, encyclopedia chapters, policy papers, user manuals) may not be well-regarded, except when the (expected) impact of their work in such outlets is recognized (e.g., a chapter in *Handbook of Social Psychology*).
7. Towards the end of the fifth year the candidate will write their thesis, publicly defend the dissertation, followed by a closed door examination by the thesis committee. Following successful completion, the student will be eligible for a PhD degree awarded by the university.
8. Before they graduate, they should aim to have some international reputation, through their published work, conference presentations, and involvement as reviewers of reputable journals.
9. All students and candidates will abide by policies and standards laid out by the committees of the University with respect to ethics, academic honesty and integrity, professional conduct, disciplinary infractions, and sexual harassment at all times.

Funding

A limited number of PhD fellowships will be offered by Ashoka University to support PhD students (as per the rules and regulations of the University). The fellowship includes a monthly stipend of INR 35,000 per month, a contingency grant of INR 20,000, and offers extensive teaching opportunities. There is no additional stipend for teaching.

The monthly stipend and annual contingency grant given to PhD students who receive other scholarships (from UGC, CSIR or a partner organization) will be decided based on terms covering the scholarship itself and as per the regulations of the University. Students will also be offered housing on campus, subject to availability). In case on-campus housing is not available, Rs. 7000 per month rent allowance will be paid towards off-campus housing.

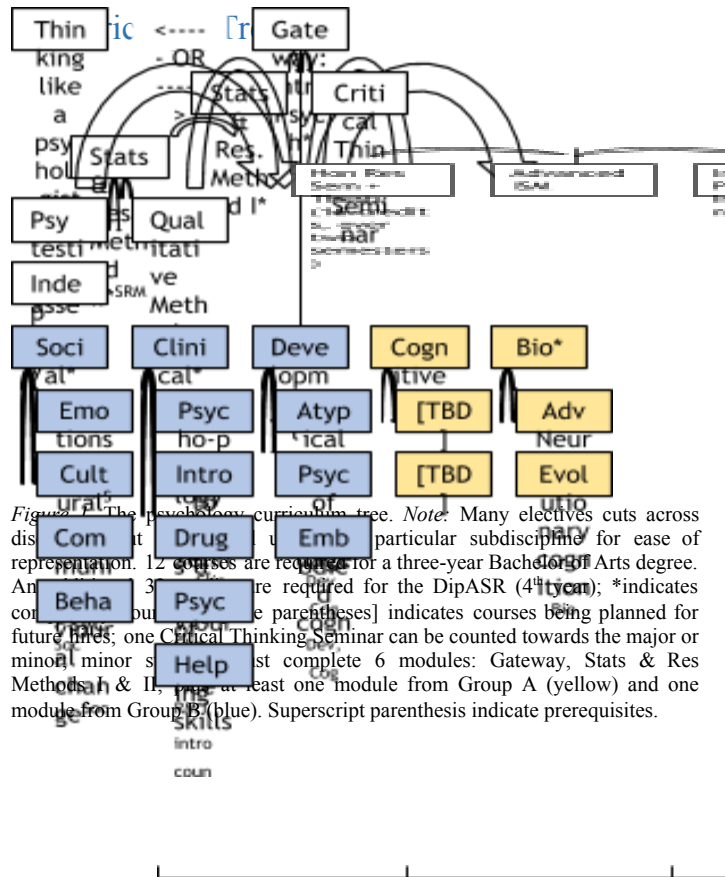

Figure 2. The psychology curriculum tree. Note: Many electives cuts across disciplines. 12 courses are required for a three-year Bachelor of Arts degree. An additional 3 courses are required for the DipASR (4-year); *indicates courses being planned for future times; one Critical Thinking Seminar can be counted towards the major or minor; students must complete 6 modules: Gateway, Stats & Res Methods I & II, and at least one module from Group A (yellow) and one module from Group B (blue). Superscript parenthesis indicate prerequisites.

Example of Course Planning for Majors and Advanced Majors

Semester 2:
Gateway or Thinking like a psychologist

Semester 3:
Stats & Res Method I
Core Domain 1
Core Domain 2

Semester 4:
Stats & Res Method II
Core Domain 3
Core Domain 4

Semester 5:
Core Domain 5
Elective 1
Elective 2

Semester 6:
Elective 3
Elective 4

Semester 7:
HRS
Elective 5

Semester 8:
Thesis (continuation from HRS)
Elective 6



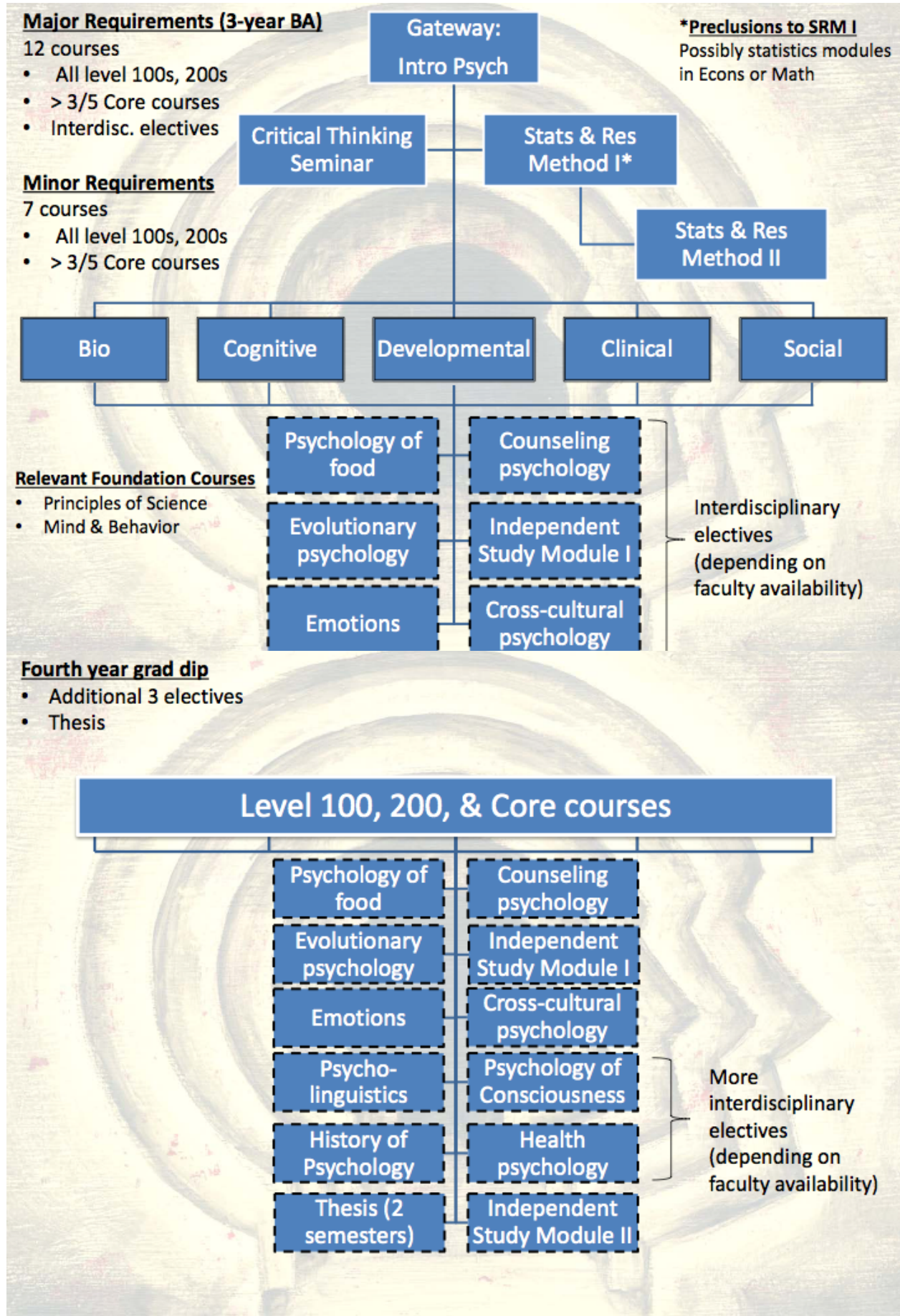

Facts and Figures

This section is meant as a historical record of the department's history.

UG enrol

2019
2020
2021

Enrollment numbers

Year of admission	No. of majors by Year 3	No. of ASP students	No. of thesis students
2014	14	7	5
2015	33	12	12
2016	56	N/A	N/A
2017	57	4	4
2018	68	20	18
2019	100	22	10

Note: Correct as at 1 Oct 2019

MLS enrollment numbers

Year of admission	No. of students enrolled	No. of students who pursued higher ed
2015	3	3 (PhDs at Univ. Maryland, Univ. Texas, Univ. Washington)
2016	1	1 (Masters at Free Univ. Amsterdam)
2017	4	0
2018	4	
2019		

Note: Correct as at 1 Oct 2018

Faculty

Name	Period
Neil Lutsky	Spring 2015; Spring 2017
Kai Qin Chan	Aug 2015 – Monsoon 2018 (tenure-track)
Annette Taylor	Monsoon 2015, Spring 2019, Spring 2021
Grant Rich	Spring 2015 (visiting)
Madhavi Maganti	Jan 2016 – present (tenure-track)
Simantini Ghosh	Aug 2016 – present (tenure-track)
Bittu Rajaraman	Aug 2016 – present (tenure-track joint appointment: bio & psych)
Sieun An	Dec 2016 – 2020 (tenure-track)
Avantika Bhatia	Aug 2017 – present (tenure-track)
Prakash Pandakannya	Jan 2018 – 2020 (Visiting professor)
Rashmi Nair	Monsoon 2018 (Visiting) & Monsoon 2019 (tenure-track)
Sramana Majumdar	Monsoon 2019 - present (Visiting) prospective applicant for tenure-track
Reetu Jain & Tripura Kashyap	Monsoon 2019 - present (Visiting)
Eleanor Hodgkin	Spring 2019 (Visiting)
Swathi Swaminathan	Monsoon 2020 - present (Visiting)
Thomas Bak	Monsoon 2020 - present (Visiting)
Sneha Shashidhara	Monsoon 2020 - present (Visiting)
Neeraj Kumar	Monsoon 2020
Shudarshana Gupta	Spring 2021 - present (Visiting)

Note: Correct as at May 2019